



AIR, MARITIME AND RAILWAY ACCIDENT
INVESTIGATION NATIONAL BOARD
9, Dyakon Ignatiy Street, 1000 Sofia, Bulgaria



Ref.:
AAIU-2021-02

Issue date:
October 24, 2022

Status:
FINAL

**SERIOUS INCIDENT, OCCURRED ON MAY 22, 2021,
INVOLVING A320-214 AIRCRAFT, REGISTRATION
MARKS LZ-FBC, OPERATED BY „BULGARIA AIR“,
PERFORMING FLIGHT FROM SOFIA TO SHARM EL-
SHEIKH**

Purpose of Report and Responsibility Level

Under Annex 13 of the Chicago Civil Aviation Convention of 07.12.1944, Regulation 996/20.10.2010 of the European Parliament and the Council on the investigation and prevention of accidents and events in Civil Aviation and Ordinance No. 13/27.01.1999 of MT (last amendment and addition - 22.01.2016), the investigation of an aviation event aims at identifying the reasons that led to the event to eliminate and exclude these in future **without identifying someone's guilt or liability**.

Contents

01.	List of abbreviations	4
1.	Introduction	5
2.1.1.	Flight number and type, the last point of departure and time, and planned destination point	5
2.1.2.	Flight preparation and description of the flights	6
2.1.3.	Location of aviation occurrence	7
2.2.	Injuries to persons	7
2.3.	Damage to aircraft	7
2.4.	Other damages	7
2.5.	Personnel information:	7
2.5.1.	Commander- PM	7
2.5.2.	Co-pilot-PF	8
2.5.3.	Cabin crew	8
2.6.	Aircraft Information	8
2.6.1.	Airworthiness Information	8
2.6.2.	Aircraft characteristics	9
2.6.3.	Information on the fuel used and its condition	10
2.7.	Meteorological information	10
2.8.	Aids to navigation	10
2.9.	Communications	10
2.10.	Aerodrome information	11
2.11.	Flight recorders	11
2.12.	Wreckage and impact information	13
2.13.	Medical and pathological information	13
2.14.	Fire	14
2.15.	Factors for Survival	14
2.16.	Tests and research	14
2.17.	Organizational and management information	15
2.17.1.	Flight Crew Operating Manual	16
2.18.	Additional information	18
3.	Analysis	23
4.	Conclusion	24
4.1.	Findings	24
4.2.	Causes	26
5.	Safety Recommendations	26
ANNEX 1	27
ANNEX 2	34

01. List of abbreviations

AAIU	- Aviation Accident Investigation Unit;
ALT	- Altitude;
AMRAUD	- Aircraft, Maritime and Railway Accident Investigation Unit Directorate
AMM	- Aircraft Maintenance Manual
ARP	- Aerodrome reference point;
ATIS	- Automatic terminal information service;
ATPL(A)	- Airline Transport Pilot License
BULATSA	- Bulgarian Air Traffic Services Authority;
CAA	- Civil Aviation Authority;
CVR	- Cockpit Voice Recorder;
DG CAA	- Directorate General Civil Aviation Administration;
EASA	- European Aviation Safety Agency;
ECAM	- Electronic Centralized Aircraft Monitor;
FDR	- Flight Data Recorder;
FH	- Flight Hour
ft	- Foot;
ICAO	- International Civil Aviation Organization;
KT	- Knots;
LBSF	- Sofia Airport
MAG	- Magnetic course
MEL	- Minimum Equipment List
MSN	- Manufacturer Serial Number;
MTITC	- Ministry of transport, information technology and communications;
QRH	- Quick Reference Handbook
p.	- page;
QNH	- Altimeter sub-scale setting to obtain elevation when on the ground;
RWY	- Runway;
SRIS	- Safety Recommendations Information System;
TLB	- Technical Log Book;
TWY	- Taxiway;
UTC	- Universal Coordinated Time;
VC	- Vicinity of the aerodrome;
MTOM	- Maximum Take-Off Mass;
PM	- Pilot monitoring;
PIC	- Pilot in command;
WPT	- Waypoint
FL	- Flight level;

1. Introduction

Date and time of the aviation event: May 22, 2021, 04:50 h. The difference between local and universal coordinated times is +3 h. All times in the report are given in UTC.

Notified: Aircraft, Maritime and Railway Accident Investigation Unit Directorate (AMRAUD) and Directorate General "Civil Aviation Administration" (DG CAA) of the Republic of Bulgaria, the European Commission, the European Aviation Safety Agency (EASA), the International Civil Aviation Organization (ICAO) and the National Bureau of Aviation Occurrences Investigation (BEA) of the Republic of France.

On the grounds of the provisions of Article 9, Para1 of Ordinance No 13 dated 27.01.1999 on Investigation of Aviation Accidents the occurrence was classified as a serious incident by the AMRAINB. The materials on the aviation occurrence have been filed in case No 02/05.2021 in Aviation Transport Unit archives at AMRAINB.

In accordance with the provisions of Article 5, para 1 of Regulation (EU) No. 996/2010 on the investigation and prevention of accidents and incidents in civil aviation, Article 142. Para. 2 of the Civil Aviation Act of the Republic of Bulgaria, dated 01.12.1972, and Article 10, para. 1 of Ordinance No. 13 of the Ministry of Transport, dated 27.01.1999, on the Investigation of Aviation Occurrences, and on the grounds of the provisions of Article 6 , para 1, point 8 of the Rules of procedure on the activity, structure and organization of the AMRAINB by Order No. RD-08-15, dated 31.05.2021 of the Chairperson of the Management Board, a Commission is appointed for investigation of the serious incident.

Summary:

On May 22, 2021, the Airbus 320-214 aircraft, registration marks LZ-FBC, operated by Bulgaria Air performing flight FB8509 from LBSF Sofia (Bulgaria) to Sharm el Sheikh (Egypt) with 139 people on board. During the climb out phase shortly after take-off, approximately 10 min after lift-off at FL225 an engine No 1 was shut down. The flight crew declared PAN PAN and returned to Sofia for a safe landing on runway 27. There were no consequences for the flight crew and the passengers.

Because of the investigation, the Commission considers that the serious incident is due to the following reason:

Root cause:

- Violations in the technological process by Lufthansa Technik Sofia personnel during the replacement of the fuel pump of the left engine of the aircraft A320-214 with registration LZ-FBC;

Underlying cause:

- Absence of comprehensive flight control by crew of engine parameters during take-off and climb in terms of comparison of rotor speed, exhaust temperature and fuel consumption;
- Lack of awareness of the flight crew of the work performed during the servicing of the aircraft before the flight.

2. Factual information

The commission received information about the realization of an aviation occurrence from written explanations from the flight crews, ground crew serving the flights, witnesses of the event and data from the BULATSA.

2.1.1. Flight number and type, the last point of departure and time, and planned destination point

Flight Number: FB8509.

Type of flight: Commercial Air Transport - Passenger – Airline-Schedule

Last point of departure: Sofia –LBSF (SOF), Bulgaria.

Take-off time: 04:50

Planned destination point: Sharm-El-Sheikh-HESH (SSH)

2.1.2. Flight preparation and description of the flights

A 180-seat aircraft A320-214 with registration marks LZ-FBC is planned to perform the flight FB 8509 of "Bulgaria Air" on 22.05.2021. The standard 6-person crew of the aircraft, consisting of the commander, co-pilot and four flight attendants, is reinforced by a technician with certain ground functions only at the final destination. The pilot in command (PIC) is the co-pilot, the pilot monitoring (PM) is the commander.

The aircraft last performed a charter flight on AO on May 7 and landed early in the morning of the 8th. After landing, the flight crew did not record any failures or malfunctions requiring technical intervention in the Technical logbook. Therefore, the maintenance staff carried out the activities foreseen in the operator's "AIRBUS A319/320 Maintenance Programme". During such inspection on 18.05.2021, fuel leakage from the main fuel pump of the left engine was found to be above the permissible standards. It was found to be over 90 drops per minute, which required its replacement. On 20.05.2021, Lufthansa Technik Sofia specialists in their hangar carried this out, and the exchange was recorded in the (TLB, Seq. No. 089894) at 19:00 h. In the following days until the flight on 22.05, no faults were found during the inspections carried out. Thus, on 22 May the aircraft was accepted by the flight crew after routine preparation for flight FB 8509. When boarding passengers, a family of three was late and had to wait 33 minutes. The doors are closed at 04:33 UTC. There are 132 passengers and 7 crew on board. The take-off mass of the aircraft is 63185 kg and the fuel on board is 9200 kg. Meteorologically the weather is excellent - clear, calm, visibility 6 km, temperature 6°C, QNH 1020. The engine start-up was executed without any peculiarities, the taxiing for Runway 09 - also. At 04:44 on takeoff run for take off the left engine went into mode with a few seconds delay. This is unusual, it was observed by the crew, but as the parameters stabilized the take-off was continued. The initial climb on the RUMEN 2S departure pattern to FL 210 proceeded without problems.

At 04:54:40, ENG 1 OIL LOW PRESSURE and Master Caution alarms sounded at FL 210

At 04:55:00, approximately 35 NM before WPT NIKTI, while crossing FL 210 in a climb, the pilot monitoring sensed a gradual decrease in the vertical speed of the climb and an urge to turn left. On checking the engine readings, by the flight crew was observed a decrease in left engine speed with no tendency to stabilize. At the same time, the pilot in command brought the problem to the attention of the pilot monitoring.

The flight crew decides to stop the climb to the 230 FL. After being convinced of the engine's self-shutdown, he decides not to attempt to restart it. He declares an emergency with the cue "PAN, PAN", requests vectoring and heads for a landing on Runway 27 at Sofia Airport. The commander informed the senior flight attendant of the situation and the decision to return and requested her to remind the cabin crew of the emergency leave an aircraft in case of necessity.

The co-pilot had been piloting the whole time, except for a little time to readjust the nav computer for the approach back to Sofia. As conditions did not prevent the single-engine flight, the landing mass was not above the allowable landing mass, and the crew had recently successfully completed training with a similar scenario, the commander did not modify the predetermined functions.

The landing was performed normally at 05:19:53 with vertical overload $N_y=1.1198$, the aircraft taxied and stopped at parking stand 12. The passengers and crew disembarked the aircraft by mobile stairs with some delay (about five minutes due to stair delays) and were bussed to Terminal 1

2.1.3. Location of aviation occurrence

The serious accident occurred on a flight en route from Sofia Airport (LBSF) to Sharm El Sheikh Airport (HESH) in Class C airspace over the territory of the Republic of Bulgaria, in the process of climbing, while crossing FL 210, 35 NM before WPT NIKTI

2.2. Injuries to persons

No injuries of crews, passengers or other persons because of the occurrence.

<i>Injuries</i>	<i>Crew</i>	<i>Passengers</i>	<i>Total in the aircraft</i>	<i>Others</i>
<i>Fatal</i>	0	0	0	0
<i>Serious</i>	0	0	0	0
<i>Minor</i>	0	0	0	0
<i>None</i>	7	132	139	<i>Not applicable</i>
<i>Total</i>	7	132	139	0

2.3. Damage to aircraft

No damage to the airframe was detected during the visual inspection performed after the completion of the flight, see Figures 1 and 2 of Annex 1.

Three bolts were found loose from the fuel line connection flange to the fuel manifold and fuel filter. The loose bolts and the resulting fuel leak can be seen in Figures 3 to 8 of Annex 1.

2.4. Other damages

No other damages.

2.5. Personnel information:

2.5.1. Commander- PM

Man	50 years old
License:	BGR. FCL ATPL (A); Issued by Bulgarian CAA Valid until 30.04.2022
Qualifications:	CAPTAIN A320.
Medical Validity:	Class 1, valid to 14.09.2021
Medical restrictions:	None.
Proficiency in English:	English Level 6.
Flight experience:	
Total Flying Hours:	10 250 FH.
Total Flying Hours on Type:	770 FH
Last check	Prof. Check, Revald. Prof. Check 10.03.2018 Line Check: 24.04.2021 r.
Information on the working hours and rest:	
For the last 24 hours:	00:00 FH;
For the last 30 days	40:05 FH
For the last 90 days:	60:00 FH.
Rest time prior to duty on 22 May 2021:	15:50 h.
Aviation events until present:	No information.

The Commission assumes that the captain possess the required qualification and medical fitness for flights in accordance with existing regulations and that there is no breach of the rules on working time and pre-flight rest periods.

2.5.2. Co-pilot-PF

Man	33 years old
License:	BGR. FCL.ATPL(A); Issued by Bulgarian CAA Valid until 31.03.2022
Qualifications:	FO A320.
Medical Validity:	Class 1, valid to 07.11.2021
Medical restrictions:	None.
Proficiency in English:	English Level 6.
Flight experience:	
Total Flying Hours:	4137 FH.
Total Flying Hours on Type:	2521 FH
Last check	Prof. Check, Line Check: 24.04.2021 г.

Information on the working hours and rest:

For the last 24 hours:	5:37 FH;
For the last 30 days:	29:50 FH
For the last 90 days:	83:16
Rest time prior to duty on 22 May 2021:	15:50 h.

The Commission assumes that the captain possess the required qualification and medical fitness for flights in accordance with existing regulations and that there is no breach of the rules on working time and pre-flight rest periods.

2.5.3. Cabin crew

As cabin crew are not related to the causes of the serious incident, no information on their qualifications is required.

The technician of aviation operator on board is not involved in the preparation of the aircraft for the flight.

2.6. Aircraft Information

2.6.1. Airworthiness Information

The A320-214, serial No. 2540, was manufactured by Airbus Industries, France. The aircraft is owned by SASOF IV (A1) AVIATION IRELAND DAC. The operator of the aircraft is Bulgaria Air with address at Blvd. Brussel 1, Sofia Airport, Sofia 1540, Republic of Bulgaria.

The three aircraft are type A321-231.

The aircraft is registered with registration marks LZ-FBC and is entered in the Register of Civil Aircraft of the Republic of Bulgaria by DG CAA on 31 July 2018 under No. 2217. The aircraft was issued an Airworthiness Certificate under No 25-0015 on 10 October 2008. The aircraft has a certified Airworthiness Review Certificate BG.MG.0020 - ARC - 2217 - 4 on 18.09.2020 with validity 22.09.2021. The aircraft was issued a Certificate of Compliance with Aviation Noise Standards on 12.10.2011 under number 45 - 0014.

The operator of the aircraft holds an Air Operator's Certificate CAO No BG 20 with date of issue 01.07.2020.

Bulgaria Air JSC holds an approved of the Continuing Airworthiness Management Organization of aircraft (CAMO) with approval number BG.MC.0020. Lufthansa Technik Sofia, holding Part 145 approval - DE.145.0001, shall perform the line and base maintenance of the aircraft of Bulgaria Air.

From the beginning of the operation until 22.05.2021, the day of the aviation occurrence, the aircraft has flown 39348:49 h and made 20741 landings.

The aircraft is equipped with two CFM56-5B4/P engines with serial numbers 577369 (left) and 577368 (right) with the same FH of 38669:57 h and 20367 cycles.

Maintenance of the aircraft is carried out based on the Airbus A319/A320 aircraft maintenance program of AO 'Bulgaria Air', edition 04, approved by the Civil Aviation Administration of the Republic of Bulgaria on 14.05.2021.

In accordance with this program:

The aircraft has issued by Lufthansa Technik Sofia Certificate of Release to Service (CRS) on February 9, 2020.

The Daily Check performance of the aircraft on 18.05.2021 was found fuel leak from the drainage of engine No. 1. It was found that the main fuel pump of the engine caused the leak. It has been replaced. The replacement was carried out on 20.05.2021 by the staff of Lufthansa Technik Sofia and the replacement work is reflected in the technical board log No. 089894, a copy of which is attached to the investigation materials. After performing the replacement work, no fuel leak was found.

On 22.05.2021 at 02 h UTC at Sofia airport the aircraft was executed Weekly + Daily Check, at 03:17 Transit Check was executed and at 04:44 the aircraft took off for the flight Sofia - Sharm El Sheikh. During the flight, the left engine switched off and at 05:19:53 h UTC the aircraft landed back at Sofia Airport. During the post-landing inspection, a fuel leak was detected from the fuel filter connection flange on the fuel injector manifold piping, Figures 4 and 7 of Annex 1. The results of the inspection were recorded in technical logbooks numbers 089898 and 089899, copies of which are attached to the investigation file. The inspection was carried out by Lufthansa Technik Sofia personnel in the presence of representatives of the AMRAINB.

After detection of the leak, it is established that three of the four bolts of the flange are loose. There is no fuel leakage during the operation of the engine of ground Idle mode. At increased engine rotor speeds, a significant amount of fuel leaks from the loose connection, causing the engine to shut itself down in flight due to excessive depletion of the fuel-air mixture in the engine combustion chambers. The Work has been carried out to restore the tightness of the said joint and to check the tightness of the joints that were removed when the fuel pump was replaced.

The airworthiness of the aircraft has been restored and the aircraft has been flying since 23.05.2021.

2.6.2. Aircraft characteristics

A320 aircraft is a narrow-body medium range passenger airplane. The type is certified by EASA with type certificate number EASA.A.064.3 and covers the requirements of CS-25.

The aircraft is equipped with two CFM56-5B4/P turbofan engines. They are located in nacelles suspended on pylons, respectively engine No. 1 to the left wing and engine No. 2 to the right wing.

The Maximum Take-Off mass of the airplane is 77000 kg. The Maximum Landing Mass is 64500 kg. For the flight in which the air occurrence was realized, in accordance with the aircraft load table prepared at Sofia Airport, the masses are as follows:

- Dry Operating Weight-43310 kg;
- cargo mass 10675 kg, including passengers, crew and baggage;
- actual mass without fuel 53985 kg;
- Total Fuel Mass on Airplane Before Flight - 9200 kg;
- actual take-off mass 63185 kg with a maximum of 77000 kg;

- the mass of fuel in the aeroplane after landing, as recorded in the technical logbook, is 7400 kg.
- the fuel spent for the flight 1800 kg;
- mass on landing 61385 kg against a maximum permissible of 64500kg;

There are no deviations from the mass and the balance of the aircraft during flight.

Typical speeds:

- Never exceed speed (V_{mo}): 350 kt CAS;
- Limiting Mach number M = 0.82;
- VD - 381 kt CAS;
- MD - 0.89;
- VLO (landing gear) extension - 250 kt;
- VLO retraction - 220 kt;
- VLE (Landing gear extended) - 280 kt.

Recommended speeds are:

- under FL 200 - 260 kt;
- above FL 200 - 280 kt.

The recommended landing approach speed-1, 23 VS1;

The maximum admissible tail-on wind at take-off and landing: 10 kt.

The technical characteristics of the aircraft are irrelevant to the realized air occurrence.

2.6.3. Information on the fuel used and its condition

Before take-off at Sofia Airport, the aircraft was refuelled with 7769 litres of JET A-1 fuel with a density of 801.3 kg/m³ at a temperature of 15 °C, in accordance with delivery note No 491965, a copy of which is attached to the investigation materials. The mass of the loaded fuel is 6225 kg.

The quantity and quality of the fuel had no influence on the realisation of the event.

2.7. Meteorological information

For the period in review from 04:00 to 05:30 h UTC on 22.05.2021, the western part of FIR Sofia is under the influence of an anticyclonic baryonic field, the air mass is stable and no dangerous phenomena were observed.

The meteorological conditions at the time of the air occurrence were of no effect to the serious incident.

2.8. Aids to navigation

The aircraft performed the flights with the standard navigation equipment for the aircraft type.

There are no reported technical failures of the navigation equipment of the aircraft.

The flights of the aircraft were carried out in air space of Bulgaria, under the conditions of zonal navigation and in conformity with the Instrument Flight Rules.

There is no information about technical failures of the navigation system of the Bulgarian Air Traffic Services Authority (BULATSA), which could cause the occurrence.

All facilities included in the national net for course navigation operated normally.

In the daily briefing statement of the ACC Sofia, no technical failures were recorded, which might directly affect the operational ability at the time of the occurrence.

2.9. Communications

The aircraft performed the flights with the standard communication equipment for the types of aircraft.

The air-ground radio communication in the FS Tower, the Approach and the aircraft serviced was carried out at the frequency of 118,100 MHz and 123.7 MHz in English.

After hearing the radio conversations at the operating frequencies of FS Tower and Approach, the Investigation Commission found that there had been no loss of radio communication and that there were no interruptions and disturbances during the radio broadcasting with not a single aircraft in the sector.

2.10. Aerodrome information

Aerodrome Location Indicator and Name – LBSF-SOFIA;
ARP coordinates and site at aerodrome - N42°41'42" E023°24'30", RWY centre;
Elevation - 1742 ft (531m);
Designations - RWY 09/27 - MAG 091°/271°;
Dimensions of RWY (m) - 3600 x 45 m;

2.11. Flight recorders

At Sofia Airport, after the aircraft landed, in the presence of a representative of the NBRPWT, the information was taken from the FDR. The full data from the decoding of the recorded parameters are given in Annex 2.

After decoding and analysing the flight parameter records from the flight data recorders, it was found that:

On 20.05.2021 the engine No.1 was started. Ground test whereby,

ENG 1 N1 19 %;

ENG 2 N1 no record;

ENG 1 N2 60 %;

ENG 2 N2 no record.

The variation of the Revolutions per minute (RPM) and EGT exhaust temperature of Engine #1 is shown in the graph on page 4 in Appendix 2.

On 22.05.2021, during flight FB-8509 from Sofia (Bulgaria) to Sharm Al Sheikh (Egypt), Engine No 1 failure 10 minutes after take-off from Sofia Airport (LBSF).. The crew shut the engine down and returned to Sofia Airport.

A diagram of the flight is shown on page 1 of Appendix 2. The sequence of the realised events of decisive importance for the flight, reflected in the FDR record, is as follows:

At 04:34:44, Start of engine #2. Anomalies of engine parameters not observed.

At 04:35:37, Start of engine #1. Anomalies of engine parameters not observed.

At 04:36:14 both engines run.

ENG1

N1 18%

FUEL FLOW 857 PPH

EGT 379 deg. C

ENG2

N1 18%

FUEL FLOW 724 PPH

EGT 412 deg. C

FUEL QTY

L INNER 8576 Lbs

L OUTER 1408 Lbs

CENTRE 64 Lbs

R INNER 8832 Lbs

R OUTER 1536 Lbs

The schedule of variation of the main parameters for the time from 04:34:11 to 04:38:17 h UTC is shown on page 8 of Appendix 2.

At 04:37:14, the flight crew started taxiing.

At 04:44:17, the aircraft took off from Runway 09:

Gross Weight 144509 Lbs

ENG1

N1 84%
FUEL FLOW 9488 PPH
EGT 678 deg. C
ENG2
N1 84%
FUEL FLOW 7123 PPH
EGT 678 deg. C
FUEL QTY
L INNER 8385 Lbs
L OUTER 1408 Lbs
CENTRE 17 Lbs
R INNER 8704 Lbs
R OUTER 1408 Lbs

For the same values of exhaust gas temperature and % RPM of both engines, the fuel consumption of engine No. 1 is 33.2% higher than that of engine No. 2).

At 04:54:40 ENG 1 OIL LOW PRESSURE and Master Caution alarms are activated. The parameters of the two engines are respectively:

ENG1
N1 27 %
FUEL FLOW 356 PPH
EGT 399 deg C;
ENG2
N1 89 %
FUEL FLOW 5152 PPH
EGT 699 deg C.

Vertical Speed- 412 ft/min.

The variation over this time period of the main parameters can be traced on the graphs set out on pages 18 and 19 of Appendix 2.

At 04:54:52, Throttle Lever Angle ENGINE 2 moved from 24.6 deg. To 34.8 deg. ENG 2 N1 90 %.

At 04:55:02 Throttle Lever Angle, Engine 1, Set to 0 degrees.

At 04:55: Fire Valve Engine 1 set to Fully Closed position. Master Caution alarm are activated

The variation over this time of the main parameters can be traced on the graphs set out on pages 22 and 23 of Appendix 2. The fuel flow to engine 1 (resulting from the high pressure rotor autorotation) is stopped.

At 04:55:55 Master Caution signal for 3 seconds..

At 04:56:17, Engine 2 thrust reduced for 5-10 seconds.

Active AP modes;

ATS Speed Mach Mode;

H/PATH sub mode NAV;

ENG1

N1 16%

FUEL FLOW 0 PPH

EGT 308 deg C;

ENG2

N1 62 %

FUEL FLOW 1492 PPH

EGT 578 deg C;

Vertical Speed- 64 ft/min.

The graphical variation of the parameters is shown on pages 25 and 26 of Appendix 2.

At 04:57:05, MAG HEADING started change from 157 deg to 330 deg.

At 05:00:35 the flight crew started to descent

At 05:05:32, the aircraft turned to HDG 084 deg.

Computed Airspeed, CAS: 252 kts;

Vertical Speed, VS: - 33 ft/min;

Altitude 14016 ft,

At 05:06:55, the aircraft turned to HDG 310 deg:

Computed Airspeed, CAS: 251 kts.

Vertical Speed, VS: 8 ft/min

Altitude 14024 ft.

At 05:13:44, the aircraft turned to HDG 270:

Computed Airspeed, CAS: 229 kts;

Vertical Speed, VS: - 928 ft/min;

Altitude 14024 ft.

At 05:14:11 SLATS 18:

Computed Airspeed, CAS: 217 kts;

Vertical Speed, VS: - 447 ft/min;

Altitude 4868 ft

At 05:14:46 FLAPS 15, SLATS 22:

Computed Airspeed, CAS: 186 kts;

Vertical Speed, VS: 202 ft/min;

Altitude 4832 ft

At 05:16 All Gears Locked Down,

Computed Airspeed, CAS: 254 kts;

Vertical Speed, VS: 864 ft/min;

Altitude 3557 ft..

At 05:16:22 FLAPS 35, SLATS 27:

Computed Airspeed, CAS: 148 kts;

Vertical Speed, VS: - 629 ft/min;

Altitude 3404 ft.

At 05:18:42 the aircraft touched down at LBSF Airport:

FLAPS 35, SLATS 27;

Gross Weight 135659 Lb

At 05:18:46 Thrust Reverser deployment. Engine 2 only is activated

At 05:19:13 the aircraft evacuated Runway via taxiway F, K, M, J, N to STAND 16

At 05:22:54 Engine 2 STOP is stopped

At 05:27:53 END OF RECORDING for the flight.

2.12. Wreckage and impact information

The occurrence was not related to the aircraft destruction.

2.13. Medical and pathological information

Because of the nature of the aviation occurrence, medical and pathological research was not performed.

2.14. Fire

No fire arising.

2.15. Factors for Survival

Sofia Airport has established an immediate response organization in case the situation develops into an emergency during the landing process. Due to the normal landing of the aircraft with one engine running, no emergency rescue action is required

2.16. Tests and research

For the safety investigation, the following activities were carried out:

1. Inspection of aircraft A320-214, serial No 2540, registration LZ-FBC, after landing at Sofia Airport, together with personnel from Lufthansa Technik Sofia.
2. Download and decoding of the FDR of the aircraft.
3. Individual converses with the flight crew of the aircraft;
4. Briefings with AO personnel responsible for the airworthiness of the aircraft.
5. Conducting a questionnaire with some of the passengers of the flight selected randomly.
6. Conduct a converse with passengers;
7. Research of the left engine condition.
8. Research and analysis of aircraft operational documentation;
9. Research of the results of Lufthansa Technik Sofia's internal investigation related to the replacement of the main fuel pump of the aircraft's left engine.
10. Assessment of the aircraft's flight performance;
11. Logical-probabilistic analysis of possible causes for the realization of the occurrence.

For Item 1 the results of the inspection of the aircraft are reflected in paragraph 2.3, paragraph 2.6.1, paragraph 2.12 and Appendix 1 of this report.

For Item2 the decoding results of the aircraft FDR are reflected in paragraph 2.1.2, paragraph 2.1.3, paragraph 2.11 and Appendix 2 to this report.

For Item 3 the results of the interviews are reflected in paragraphs 2.1.2, 2.12 and 2.15.

The research conducted on Item 5 and Item 6 has as a result the following:

In fact, those 10 minutes after take-off, Engine No 1 failed and flamed out. During the take-off phase, along with higher engine vibrations, increased fuel pressure and mass flow have been able to overstrain and dislodge the partially loosen gasket, causing a massive fuel leak and loss right at the entrance of the Fuel Nozzle Filter in nacelle of Engine No 1.

The Commission decided to conduct a survey of the passengers in the cabin of the aircraft. The questionnaire was carried out based on random sampling and 16 randomly selected passengers were given a questionnaire with the following contents:

ANONYMOUS QUESTIONNAIRE

1. You travelled on 22 May on a plane A320, registration LZ-FBC, of the airline "Bulgaria Air" on the route Sofia - Sharm El-Sheikh (Sharm-El-Sheikh), where the flight was terminated:

- No;
- Yes.

2. Did you notice any irregularities during the flight?

- No;
- Yes,

If yes, describe what you noticed.

3. Did you notice any unusual smell in the cabin of the aircraft during the flight?

- No;
- Yes,

If yes, what was it and to the best of your ability, identify its strength as faint, noticeable, strong.

The Air Safety Investigation Board thanks you for your kindness in completing the questionnaire."

All respondents answered yes to the first question.

On the second question, 12 comments were indicated in 16 questionnaires. The committee grouped these comments as follows:

- Noticed plume of smoke or fog following left engine - 2 notes;
- Uncharacteristic noise at certain stages - 3 notes;
- Noise resembling howling in return flight - 2 notes;
- Tension in the flight attendants - 4 notes;
- Left engine out and return to Sofia airport - 1 note.

On the third issue, 6 notes were made relating to the presence of an odour in the cabin as follows:

- Presence of a strong smell of fuel - 4 notes;
- Presence of faint fuel odour - 1 note;
- Presence of burnt smell -1 note.

With this inquiry, the commission seeks to ascertain whether conditions have developed in the passenger compartment that are hazardous to the life and health of the occupants related to excessive saturation of fuel vapours entering the passenger compartment from the air conditioning system drawing air from the engine compressors. It is also possible that the presence of fuel odour could serve as a diagnostic of the presence of a fuel leak on board the aircraft.

From the results of the survey, the Board accepts that no conditions endangering the life and health of passengers and cabin crew were created in the passenger cabin of the aircraft. This conclusion is also supported by the interview with cabin crew.

It is also concluded that the presence of a fuel vapour odour in the passenger cabin cannot in this case serve as a basis for diagnosing a fuel leak on board the aircraft.

In an interview with a female passenger on the flight, some delay in deplaning after landing was also noted, as reflected in paragraph 2.1.2.

The research carried out under item seven, eight and ten are reflected in paragraphs 2.6.1 and 2.6.2. The research of the results of the Lufthansa Technik Sofia internal investigation relating to the replacement of the main fuel pump on the left engine of the aircraft is set out in paragraph 2.18.

A logical-probabilistic analysis of possible causes for the realisation of the occurrence is carried out in Chapter 3 of this report.

The materials from the interviews and analyses have been attached to the case for investigation of the serious incident.

2.17. Organizational and management information.

The aviation occurrence was realized by the flight crew with A320-214 aircraft on a flight from Sofia Airport (LBSF) to Sharm El Sheikh Airport (SSH).

Bulgaria Air Ltd. with approved CAO No BG20 from DG CAA operated the aircraft with date of issue 01.07.2020.

The organisation and management of Bulgaria Air Ltd. are set out in the Operational Manual Parts A, B, C and E, copies of which have been provided by AO to the Commission for use of the necessary information and are attached to the investigation file.

AO "Bulgaria Air" holds an approved organization for the management and maintenance of the continuing airworthiness of aircraft (CAMO) with approval number BG.MC.0020. Lufthansa Technik Sofia, holding Part 145 approval - DE.145.0001, shall perform the line and base maintenance of the aircraft of Bulgaria Air.

The maintenance of the aircraft is carried out based on the Maintenance Programme for AIRBUS A319/A320 aircraft of Bulgaria Air, edition 04, approved by the Civil Aviation Administration of the Republic of Bulgaria on 14.05.2021.

2.17.1. Flight Crew Operating Manual

2.17.1.1. Abnormal and Emergency Procedures - FUEL LEAK –Bulgaria Air

 A318/A319/A320/A321 FLIGHT CREW OPERATING MANUAL	PROCEDURES ABNORMAL AND EMERGENCY PROCEDURES FUEL
--	---

(QRH) FUEL LEAK

Ident: PRO-ABN-FUEL-00018665.0002001 / 28 MAY 20
 Applicable to: MSN 02540-02596, 03780

A fuel leak may be detected, if:

- The sum of FOB and FU is significantly less than FOB at engine start or is decreasing, or
- A passenger observes fuel spray from engine/pylon or wingtip/sharklet, or
- The total fuel quantity is decreasing at an abnormal rate, or
- A fuel imbalance is developing, or
- Fuel quantity in a tank is decreasing too fast (leak from engine/pylon, or hole in a tank), or
- The Fuel flow is excessive, N1 is low (leak from engine), or
- Fuel is smelt in the cabin.

If visibility permits, leak source may be identified by a visual check from the cabin.

WHEN A LEAK IS CONFIRMED

LAND ASAP

- **Leak from engine/pylon confirmed by excessive fuel flow, low N1, or visual check:**

THR LEVER (affected engine).....IDLE
 ENG MASTER (affected engine).....OFF
 FUEL X FEED..... AS RQRD

If the leak stops, the crossfeed valve can now be opened to re-balance fuel quantity, or to enable use of fuel from both wings.

DO NOT RESTART AFFECTED ENGINE

- **Leak from engine/pylon not confirmed or leak not located:**

Stop any fuel transfer, and then monitor the depletion rate of each inner tank, to determine if the leak is from an engine or a wing, or from the Center tank, or the APU feeding line.

FUEL X FEED.....MAINTAIN CLOSED

The crossfeed valve must remain closed to prevent the leak from affecting both sides.

CTR TK PUMP 1.....OFF

CTR TK PUMP 2.....OFF

Each engine is fed via its associated inner tank only.

INNER TANK FUEL QUANTITIES..... MONITOR

Monitor the depletion rate of each inner tank.

Continued on the following page

 A318/A319/A320/A321 FLIGHT CREW OPERATING MANUAL	PROCEDURES ABNORMAL AND EMERGENCY PROCEDURES FUEL
--	---

[QRH] FUEL LEAK (Cont'd)

- **If one inner tank depletes faster than other by at least 300 kg (660 lb) in less than 30 min:**

An engine leak may still be suspected. Therefore:

THR LEVER (engine on leaking side)..... IDLE
 ENG MASTER (engine on leaking side)..... OFF
 CTR TK PUMP 1..... ON
 CTR TK PUMP 2..... ON
 FUEL LEAK..... MONITOR

 - **If leak stops:**

ENGINE LEAK CONFIRMED
 FUEL X FEED..... AS RQRD
 DO NOT RESTART AFFECTED ENGINE
 - **If leak continues (after engine shutdown):**

WING LEAK SUSPECTED
 ENGINE RESTART..... CONSIDER

CAUTION Do not apply the FUEL IMBALANCE procedure. Approach and landing can be done, even with one full wing/one empty wing.
- **If both inner tanks deplete at a similar rate:**

LEAK FROM CENTER TANK OR APU FEEDING LINE SUSPECTED

 - **If fuel smell in cabin:**

APU..... OFF
This prevents additional fuel loss through the APU feeding line.
 - **When fuel quantity in one inner tank less than 3 000 kg (6 600 lb):**

CTR TK PUMP 1..... ON
 CTR TK PUMP 2..... ON
- **For landing: DO NOT USE REVERSERS**

2.18. Additional information

At paragraph, 2.6.1 of this report it is stated that on 22.05.2021 at 04:44 h UTC the aircraft departed for the Sofia - Sharm El Sheikh flight. During the flight, the left engine switched itself off and at 05:18 h, it landed back at Sofia airport.

During the inspection performed after landing, a fuel leakage was found from gasket between fuel hose tube and fuel filter.

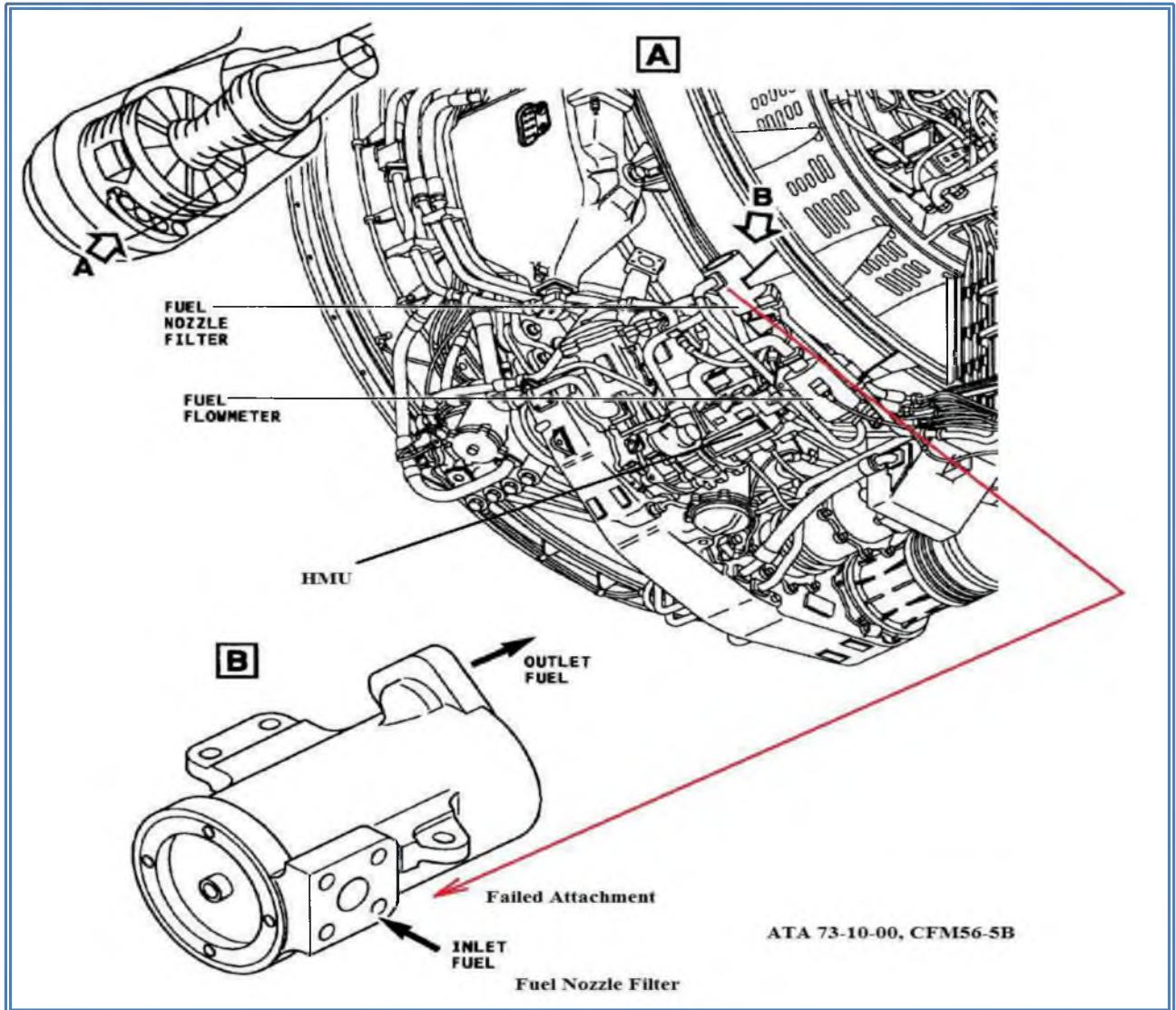

Fig.1

After the detection of the leak is established, that bolts connecting fuel hose/tube to fuel filter were not tightened properly. No fuel leakage is observed through the loose connection flange when the engine is operating mode "Idle" on ground. During the take-off phase, along with higher engine vibrations, increased fuel pressure and mass flow have been able to overstrain and dislodge the partially loosen gasket, causing a massive fuel leak and loss right at the entrance of the Fuel Nozzle Filter, which leads to Engine No 1 failed and flamed out.

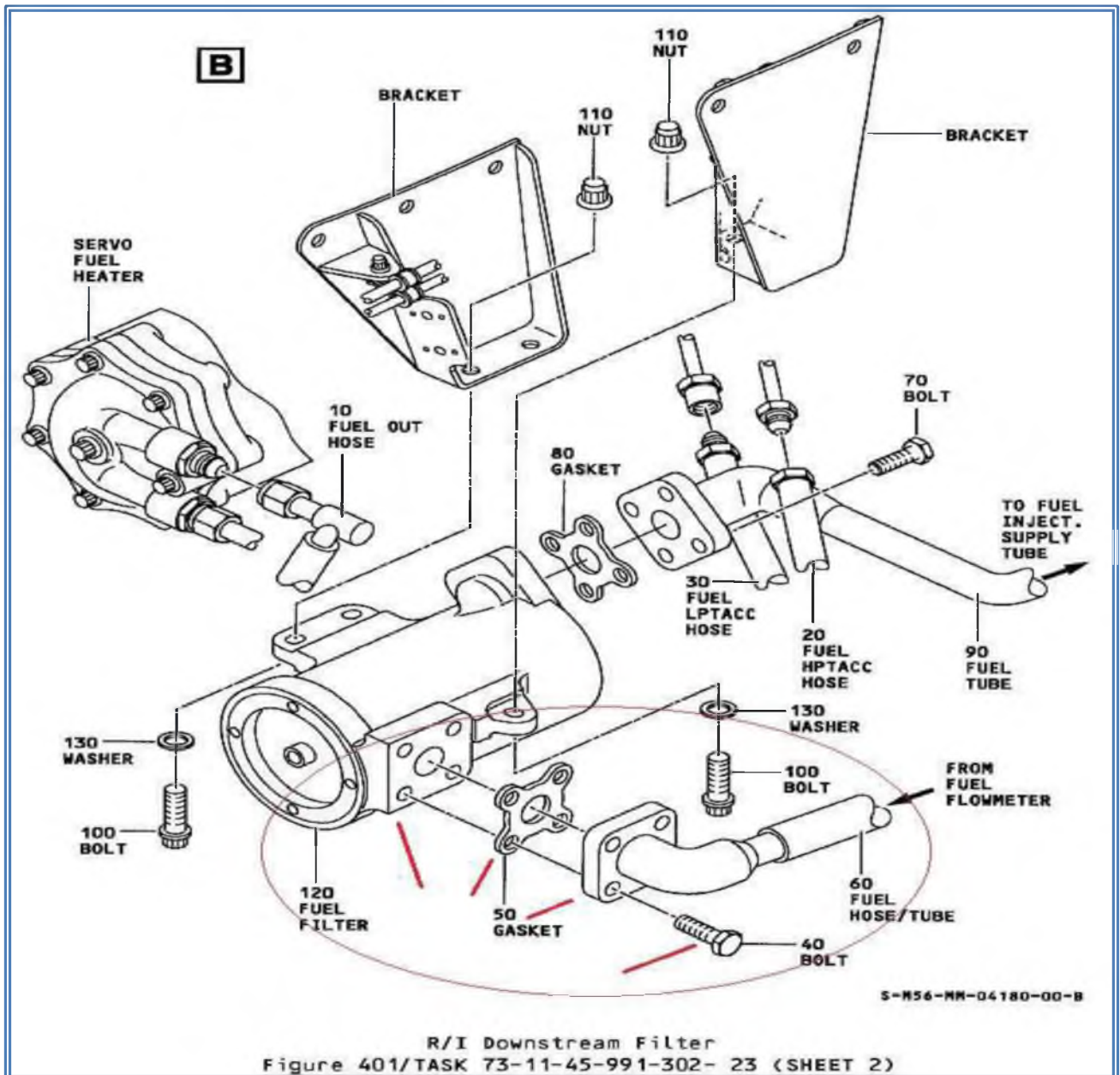

Fig.2

It was established that On 18 May 2021 during performed daily check found leakage of fuel from ENG No 1 drain must The leak was caused by the main engine fuel pump and it has been replaced. Lufthansa Technik Sofia personnel carried out the replacement on 20.05.2022 and certified in TFLB that fuel pump requires replacement and opened item in TFLB: "Replace ENG#1 fuel pump".No 089894, a copy of which is attached to the investigation file. No fuel leakage was detected after the replacement, which involved the removal and installation of the above filter.

Lufthansa Technik Sofia is carrying out an independent investigation into the circumstances and factors influencing the failed of engine No 1 of aircraft A320-214 with registration LZ-FBC. The results of the investigation have been published as a report and have been submitted to an investigation Commission appointed by the Aircraft, Maritime and Railway Accident Investigation Directorate (AMRAID)" of the Republic of Bulgaria. The report of Lufthansa Technik is attached to the investigation file and Chapter 4 'Results of the investigation' of this report is referenced below in this paragraph.

“ ...

Investigation result

1. Fault Analysis / Chain of event

Problem Statement

Following in-flight engine shut down, found that bolts connecting fuel hose/tube to fuel filter were not tightened properly.

*Chain of event

After the In-flight engine shut down on scheduled flight Sofia -Sharm El Sheikh (22 May 2021) on a/c registration LZ-FBC, the crew reported in the TFLB "ENG #1 failed in flight".

Following the in-flight engine shut down, the following actions were performed:

1. Data from DFDR is downloaded and provided to National "The Aircraft, Maritime and Railway Accident Investigation Directorate (AMRAID)".
2. Fan cowl and thrust reverse are opened - found fuel leakage on fan cowls and front half of the engine before the hot section. No reason could be determined.
3. FADEC monitoring test performed. Passed successfully.
4. Performed wet monitoring procedure. When Master switch on position and fuel flow 120 kg per hour - strong fuel leakage from gasket between fuel hose tube and fuel filter.
5. Wet monitoring procedure cancelled.
6. 3 (from 4 bolts) were found to be loosened.

During the investigation, the following was found:

On 18 May 2021 during performed daily check found leakage of fuel from ENG#1 drain must. Performed trouble shooting as per TSM 71-00-00-810-826-A. Found fuel leak from ENG#1 fuel pump more than 90 drops/min. Colleague certified in TFLB that fuel pump requires replacement and opened item in TFLB: "Replace ENG#1 fuel pump".

During internal capacity steering meeting on the same day was planned that the fuel pump change will be started on the next day and two colleagues L1 (colleague A) and L2 (colleague B) will support Line Maintenance activity. The period is close to "hour-bank clearance" which is performed on 22nd May and there are colleagues from Line Maintenance sent in compensation due to positive account of hours in their personal hour-banks. Line Maintenance colleagues will not be enough for the scheduled tasks for the next day and that's why support is planned from base maintenance colleagues. On 19 May 2021 (first day) during the morning meeting of Line Maintenance B1 mechanic (colleague C) was informed that he will be responsible for the fuel pump change together with two colleagues from the hangar.

19 May 2021 Colleagues A (Level 1 BM authorization), and B (Level 2 BM authorization) started work on 19 May (first day) with providing access and removing components. Colleague C stated that he only went to see them and discuss with them what needs to be done. He hasn't performed any maintenance on the first day.

Experience of colleagues A, B and C checked and all of them have performed similar tasks during their maintenance experience.

There was no raised defect job card where to certify performed maintenance on the first day. As per the words of the mechanics A and B, they haven't got Job Card but they worked as per approved AMMs which they have printed. 20 May 2021

On 20 May 2021 (second day) three colleagues worked together. When colleague C went to the hangar in the morning, there was IT problem, Air Nav system was not accessible and they could not print the AMMs but he went to the Line Maintenance office (outside the BM hangar area) and printed all needed manuals from there.

Defect Job Card 5001080302-0010 Engine#1 fuel pump defect was raised on the second day. The defect job card was raised iaw AMM 73-11-10/401 rev. May 21

When comparing AMM steps with JC steps it could be found that step (2) from subtask 73-11-10-010-062-A is not documented in the Job Card. Step "Remove the fuel filter (ref. AMM task 73-11-10-000-004) and inspect the fuel filter (ref. AMM task 73-11-10-210-003)" is not written down in the Job Card. Instead the missed step in the Job Card is added step 0020: "ENG#1 fuel rate flow transmitter removed iaw AMM 73-11-10/401. rev. May/21". Based on the interviews:- Colleague C added step 0020 Fuel rate flow transmitter removal

This step needs to be performed in regards with HMU removal. The AMM is different than written down in the JC. Correct AMM is 73-31-10 PB 401 - step 0040 for removal of servo fuel heater is not performed (certified as performed). Servo fuel heater stayed connected to ENG#1 oil/fuel heat exchanger

On the second date are certified removals of components from first day and installation of components from second day. Step-0020 to 0055 REM performed by A and B • Eng#1 fuel rate flow transmitter removed Eng#1 oil/fuel heat exchanger removed • Eng#1 servo fuel heater removed

- Eng#1 hydromechanical unit removed

- Eng#1 fuel pump removed (P/N: 724400-2 S/N: YA008174-8)

Step-0060 to 0160 INS performed by B and independent inspection performed by C

- Eng#1 fuel rate flow transmitter installed incl. independent inspection • Eng#1 oil/fuel heat exchanger installed incl. independent inspection • Eng#1 servo fuel heater installed incl. independent inspection

- Eng#1 hydromechanical unit installed incl. independent inspection • Eng#1 fuel pump installed incl. independent inspection (P/N: 724400-2 S/N: YA008512-9)

Step-0170 to 0180 SER performed by B and independent inspection performed by C

- Eng#1 fuel filter replaced incl. independent inspection Step-0190 and 0230 OPC performed by C

- Eng#1 wet motoring check performed

- Eng#1 FADEC ground test performed Step-0250 MAT performed by C • Used material documented

- used calibrated tools - not documented One of the required torque wrenches was booked via the SAP system on the project. According to the interview: the second required torque wrench was shared with colleagues from ENG station Bay 3 (no evidence). No tools are recorded in the Job Card at all.

During performed interviews with mechanics from different teams, they confirmed that they record tools that are used by them. Steps-0200, 0220 and 0240 independent inspections performed and certified by colleague D (B1 LM authorization) Step - 0210 performed and certified by colleague E (B1 LM authorization)

- Eng#1 minimum idle check performed Defect Card Control Check box signed off by colleague D. According to the interviews: Last required parts for installation received around 3:30 p.m.

Category:	F - Individual factors
Causes:	F03 - Time pressure F05 - Complacency F13 - Situation awareness
Description:	<p>F03 As contributing factor - some of the parts were delivered late and colleagues were trying to finish the job without accumulating additional overtime and without need to transfer not finished job to the next shift.</p> <p>F13 When creating the defect Job Card, AMM was not followed strictly. There was no documented maintenance in regards with disassembly of fuel hose/tube from gasket and fuel filter. Mechanics did not pay attention on this and when they started to assemble, there was no step in the job card to remind them and to check the bolts. AMM references which are written down on the job card are not correct for all steps. There is one general reference written down but there are different references for different tasks, as per the AMM. It could not be accounted that this is due to Human Factor mistake.</p> <p>F05 Mechanic C explained that generally when performing maintenance he is used to "follow the best practices based on previous experience".</p>

In the current event some parts are not disassembled as required while other components are removed in addition for easy access.

Category: G - Environment/ Facilities

Causes: G08 - Wind

Description: G08 As contributing factor - During interviews mechanics stated that it was windy outside in the afternoon.
Colleague C said that he went to hangar for a while and then returned back to continue work.

Category: H - Organizational factors

Causes: H07 - Work process/ procedure not followed

Description: H07 Person B and Person C haven't performed independent inspections as such.
They are fully aware about the internal rules for independent inspections and it's not based on missing knowledge.

Category: J - Communication

Causes: J02 - Between staff

Description: J02 Installation of components on the second day was done by several people. When interviewed who performed what, there were items for which they were not sure who performed them and could not remember and provide details..."

Due to bad weather conditions (strong wind), some of the tasks were performed inside the hangar (e.g. fuel pump and HMU assembly) While working outside due to strong wind, colleague C was entering the hangar from time to time Colleagues A and B were working until 6:00 p.m. and then colleagues from LM informed them that they will finish the 2 drain tubes which were left. A and B stamped the Job Card and went home. LM colleagues C, D and E performed tests – ENG#1 wet motoring check, FADEC, Engine Run Idle and tests passed successfully. There were no evidences for leakage which could notify for bolts not torqued properly and the only safety net is the inspector to perform direct supervision during maintenance. 21 May 2021 Aircraft stayed in front of the hangar until the afternoon. 22 May 2021 Aircraft scheduled for flight Sofia -Sharm El Sheikh After return from flight and found loosened bolts the following actions were performed in addition: 1. Bolts are torqued with the needed range as per the approved data. 2. Performed engine idle and then full Engine run. No traces of fuel leakage. 3. Gasket between the fuel hose tube and the fuel filter is changed. 4. All bolts (which were removed when the fuel pump was installed on 20.05.2021) were inspected and torqued again, as per the AMM. 5. Full Engine run passed successfully.

2.Cause Analysis (based on MEDA contributing factors)

Category: B - Equipment/ Tools/ Safety equipment

Causes: B11 - Not used

Description: B11 Torque wrench with the range between 47 and 51 lbf.in (0.53 and 0.58 m. da N) was not clocked on the job card and could not be confirmed that is used for torquing of bolts.

During the interviews mechanics explained that they have taken from colleague who clocked torque wrench on another project.

No tools are recorded in the Job Card at all.

It was checked and it was determined that it was not a group norm but it was single failure of the process.

In accordance with the above, during the process of replacing the main fuel pump of the Engine No1, a number of violations process were made by the Lufthansa Technik Sofia personnel carrying out the work. These irregularities are identified in the above-mentioned 'Root Cause Analysis', which was carried out based on a methodology known as MEDA (Maintenance Error Decision Aid). The Serious Incident Investigation Commission accepts this analysis.

3. Analysis

The serious incident is associated with a fuel leak from the left engine and self-shutdown, caused by flame-out in the combustion chambers due to excessive fuel impoverishment.

Initially, a situation has arisen the hazards the flight safety related to the leakage of fuel in the nacelle of Engine No 1, and subsequently this situation has grown into another situation threatening the safety of flight related to self-shutdown of Engine No 1.

In investigating the causes of the fuel leak, mainly as indicated in paragraphs 2.6.1 and 2.18, the Commission concludes that a decisive influence on its occurrence was due to the technological process failures in the replacement of the main engine fuel pump by Lufthansa Technik Sofia personnel. These violations led to the presence of a leak, but this leak should have been detected in the subsequent engine performance test foreseen in the job card. This did not happen as the test recommended by the manufacturer is performed with the operation of the engine at Minimum Idle mode.

The leak occurs at elevated engine operating modes, but these tests are not recommended by the manufacturer due to the low frequency of such events and the high cost of performing the tests.

It is worth noting the fact that the flight crew was not informed, and he did not take the initiative to be informed by the on-board documentation about the change of the fuel pump on the left engine. Such an awareness would focus the same earlier on the normal operation of this engine and would support the early detection of the fuel leak and the corresponding termination of the flight.

Some indications would also allow this to happen immediately after take-off. For example, the deviation of the aircraft nose to the left when the engines with take-off thrust, the increased fuel consumption of the left engine after its start (detected by decoding the flight data recording).

According to the crew's explanations, there is no established procedure in the climb process as to when and what engine parameters should be monitored with the result that on the flight in question the difference in fuel consumption of the two engines reaches 33.2% and this goes unnoticed by the crew.

The crew reacted when the engine switched itself off. In FCOM- Abnormal and Emergency Procedures - FUEL-FUEL LEAK of Bulgaria Air JSC it is written that in such conditions the flight should be terminated immediately.

For the transition from a situation associated with the presence of a fuel leak from the left engine in flight to a situation associated with the left engine shutting itself down occurred spontaneously, without flight crew intervention.

Upon detection of the engine shutting itself down, the crew makes the decision to abort the flight and return to the airport from which it took off. These measures were successful and the flight ended without further consequences to the passengers, crew and aircraft.

Taking into account the aforementioned in the report circumstances related to the realization of the investigated serious incident and the established causal links, the Investigation Committee considers that the dominant influence on its occurrence and development were:

In view of the circumstances mentioned above in this report related to the realization of the serious incident under investigation and the established causal links, the Commission considers that the dominant influence on its occurrence and development was exerted by:

- Violations in the technological process during the replacement of the main fuel pump of the left engine of the aircraft A320-214 with registration LZ-FBC by Lufthansa Technik Sofia personnel;
- The Minimum Idle Check for fuel leaks, following engine fuel pump replacement, as proposed by the manufacturer and it is justified in terms of the low level of risk of occurrence and economic viability.
- Absence of comprehensive flight crew control of engine parameters during take-off and climb in terms of comparison of rotor speed, exhaust temperature and fuel consumption;
- Lack of awareness of the flight crew of the work performed during the servicing of the aircraft before the flight.

4. Conclusion

4.1. Findings

As result of the investigation, the Commission made the following conclusions:

1. The aircraft A320-214, MSN 02540, as manufactured by Airbus Industries, France. SASOF IV (A1) AVIATION IRELAND DAC owns the aircraft.
2. The aircraft is registered with registration marks LZ-FBC and is entered in the Register of Civil Aircraft of the Republic of Bulgaria by DG CAA on 31 July 2018 under No 2217.
3. The operator of the aircraft is Bulgaria Air AD with the address in Sofia. "Brussels Airport, Sofia 1540, Republic of Bulgaria. The operator of the aircraft holds an Air Operator's Certificate CAO No BG 020 with date of issue 01.07.2020.
4. Bulgaria Air JSC has an approved organisation for the management and maintenance of the continuing airworthiness of aircraft (CAMO) with approval number BG.MC.0020.
5. Lufthansa Technik Sofia, approved under Part 145 - DE.145.0001, performs the line and base maintenance of the aircraft of JSC „Bulgaria Air“.
6. The aircraft A320-214, have been certified, equipped and serviced in accordance with existing regulations.
7. From the beginning of the operation until 22.05.2021, the day of the aviation occurrence, the aircraft has flown 39348:49 h and made 20741 landings.
8. The aircraft A320-214 have certificates of airworthiness -BG.MG.0020 – ARC – 2217 – 4 issued on 18.09.2020 г. and valid to 22.09.2021.

9. Lufthansa Technik Sofia issued a Certificate of Release the aircraft to Service (CRS) on 09.02.2020.
10. The aircraft is equipped with two CFM56-5B4/P engines with serial numbers 577369 (left) and 577368 (right) with the same FH of 38669:57 h and 20367 cycles.
11. During the execution of the Daily Check on 18.05.2021, a fuel leak was detected in the engine drain of engine No. 1. The leak was found to be caused by the main engine fuel pump. It was replaced.
12. Lufthansa Technik Sofia personnel replaced the fuel pump on 20.05.2021. The replacement work is recorded in technical logbook No 089894. No fuel leakage was detected after the replacement work.
13. On 22.05.2021 at 02:00 UTC Weekly + Daily Check was performed at Sofia Airport, at 03:17, Transit Check was performed and at 04:44, the aircraft took off for the flight Sofia - Sharm El Sheikh.
14. During the flight the left engine switched itself off and at 05:19:53 h UTC, the aircraft returned and landed at the Sofia airport.
15. During the inspection performed after landing, a fuel leakage was found from gasket between fuel hose tube and fuel filter.
16. After detecting the leak, three of the four flange bolts were found to be loose.
17. The work documentation associated with the fuel pump replacement lacked information on the tool used to tighten the bolts.
18. In the AMM (Aircraft Maintenance Manual) of an A320 aircraft, a leak test after a main fuel pump replacement is performed at mode Idle. Such a test was performed, but the leak did not show up on this mode.
19. At increased engine rotor speeds, a significant amount of fuel leaks from the loose connection, causing the engine to shut itself down in flight due to excessive depletion of the fuel-air mixture in the engine combustion chambers.
20. The Engine No. 2 operated without problems during the flight.
21. The mass and balance of the aeroplanes were within the permissible limits.
22. The flight crew of the aircraft includes the commander, co-pilot and four flight attendants.
23. The flight crew of three aircraft, Commanders and Co-pilots, possess the required qualification and medical fitness for flights in accordance with existing regulations.
24. There is no breach of the rules on working time and pre-flight rest periods of the flight crew.
25. The flight crew was not informed of any work being carried out to restore the airworthiness of the aircraft after the flight preceding that in which the serious accident occurred.
26. The flight crew, while monitoring the instruments controlling the engine operation, ignored the fuel indicator readings, thereby allowing the left engine to shut itself down in flight.
27. After self-shutdown of the left engine, the flight crew shall declare an emergency "PAN, PAN" and by their actions shall contribute to the ending of the situation threatening the safety of the flight with a favourable outcome.
28. The landing was performed normally at 05:19:53 with a vertical overload $N_y=1.1198$, the aircraft taxied and stopped at stand 12.
29. Passengers and crew leave the aircraft by mobile stairs with some delay (about five minutes, due to stairs delay).
30. The serious incident occurred on a flight en route from Sofia Airport to Sharm El Sheikh Airport in airspace class C over the territory of the Republic of Bulgaria, in the initial climb, crossing FL 210, 35 NM before WPT NIKTI.
31. The meteorological conditions at the time of the air occurrence were of no effect to the serious incident.
32. The use of FDR recordings allows clarifying the flight parameters at all stages of the flight, from departure from Sofia Airport to landing back at Sofia Airport.
33. No CVR audition was performed.

34. There is no information that physiological factors or incapacitation affected the crew's performance.
35. The procedures applied by the operator when organising and conducting flights are developed in accordance with the requirements of the regulations and are approved by DG CAA.

4.2. Causes

Based on the analysis performed, the Commission points out that the serious incident resulted from the following causes:

Root cause:

- Violations in the technological process by Lufthansa Technik Sofia personnel during the replacement of the fuel pump of the left engine of the aircraft A320-214 with registration LZ-FBC;

Underlying cause:

- Absence of comprehensive flight control by crew of engine parameters during take-off and climb in terms of comparison of rotor speed, exhaust temperature and fuel consumption;

- Lack of awareness of the flight crew of the work performed during the servicing of the aircraft before the flight.

5. Safety Recommendations

Taking into account the causes of the serious incident and the deficiencies found in the investigation, the Commission recommends that the following measures should be taken to ensure the flight safety:

BG.SIA-2021/02/01. Lufthansa Technik Sofia to provide in its safety management programme appropriate actions related to the prevention of violations of the line maintenance process, as reflected in the organisation's report of the internal investigation of the causes of the engine No 1 failure of flight of aircraft A320-214 with registration marks LZ-FBC on 22.05.2021.

BG.SIA-2021/02/02 The operator "Bulgaria Air" to include in the crew training program a simulator training exercise, which would simulate the circumstances arising from the serious accident.

BG.SIA-2021/02/03. The operator "Bulgaria Air" to include in the OM of the organization a procedure which ensures that the flight crew on each flight is informed of minor repairs carried out during the line maintenance of the aircraft.

The Investigation Commission reminds all organizations, to which flight safety recommendations are sent that, on the grounds of Article 18 of Regulation (EU) 996/2010 on Investigation and Prevention of Accidents and Incidents in Civil Aviation and Article 19, paragraph 7 of Ordinance No. 13 on the Investigation of Aviation Accidents are obliged to notify the Air, Maritime and Railway Accidents Investigation National Board in writing of the action taken on the recommendations made.

AIR, MARITIME AND RAILWAY ACCIDENTS INVESTIGATION NATIONAL BOARD

COMMISSION ON INVESTIGATION OF THE SERIOUS INCIDENT

Sofia

October 24, 2022

ANNEX 1



Fig. 1



Fig. 2

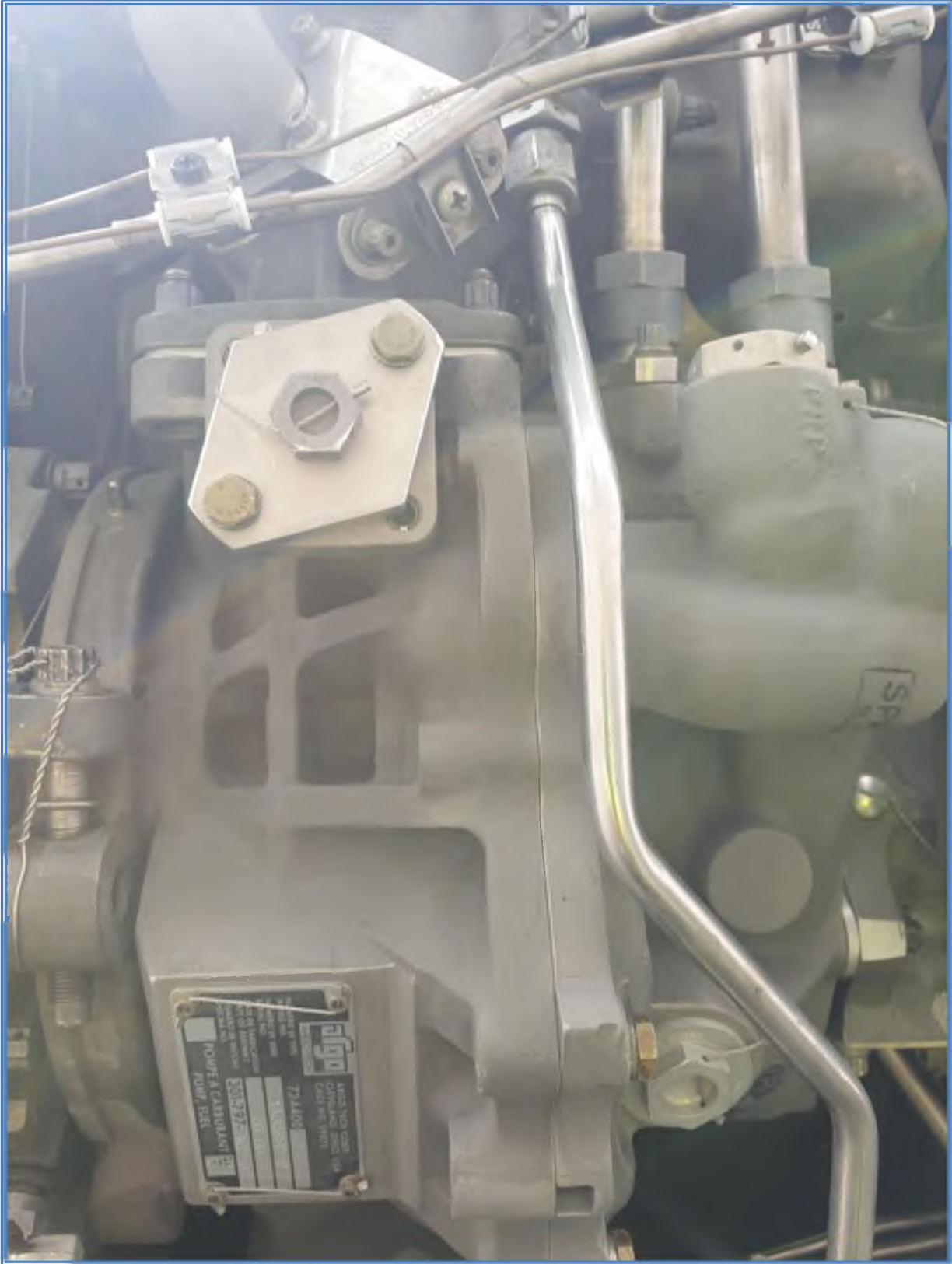

Fig. 3



Fig. 4



Fig. 5



Fig. 6



Fig. 7



Fig. 8



ANNEX 2

1. Event Summary

LH Engine failure 10 minutes after take-off from Sofia Airport (SOF). The crew shut the engine down and returned to Sofia Airport. Flight FB8509 from Sofia (Bulgaria) to Sharm el Sheikh (Egypt).

Location: SOF

Date: 22.05.2021

Operator: Bulgaria Air

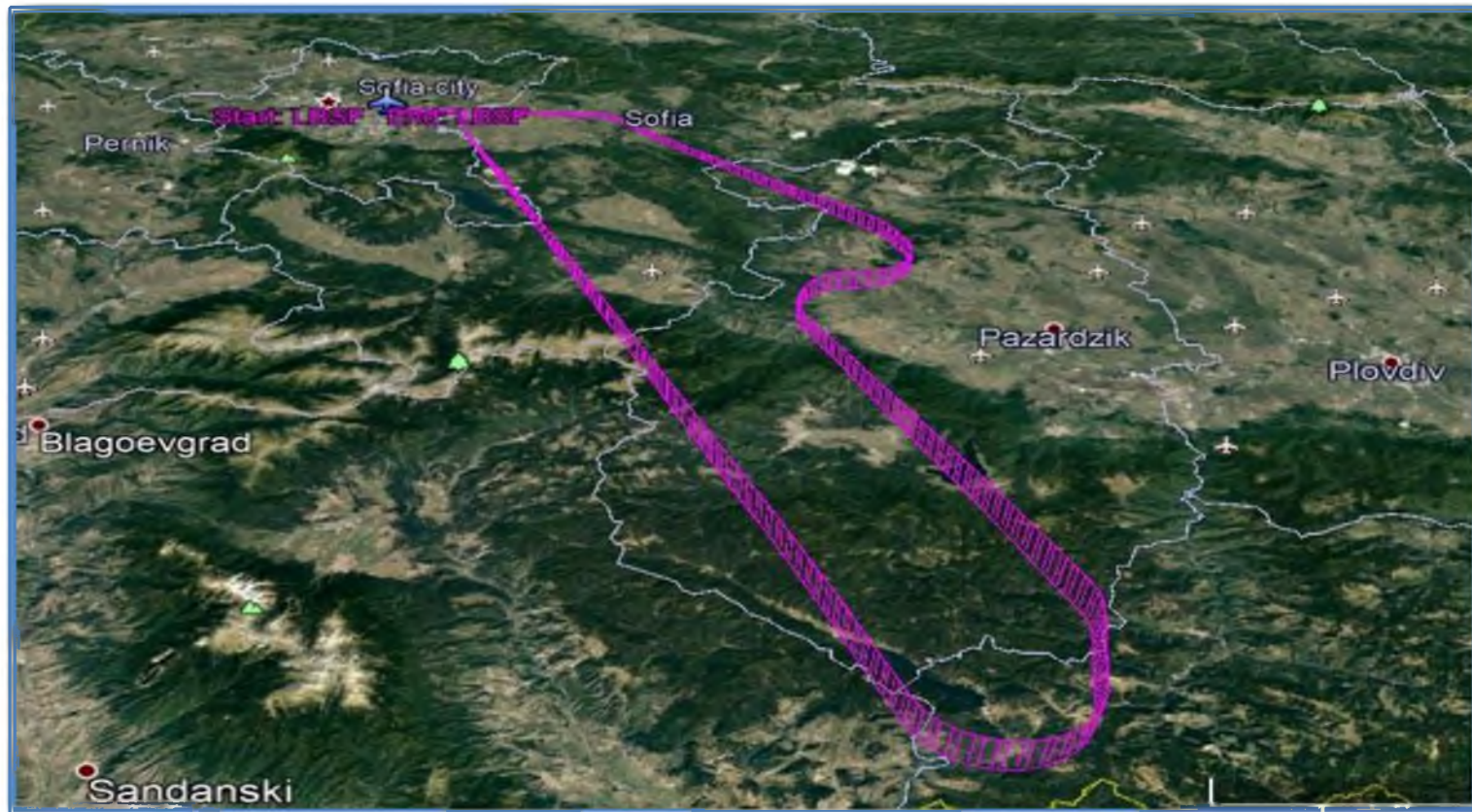

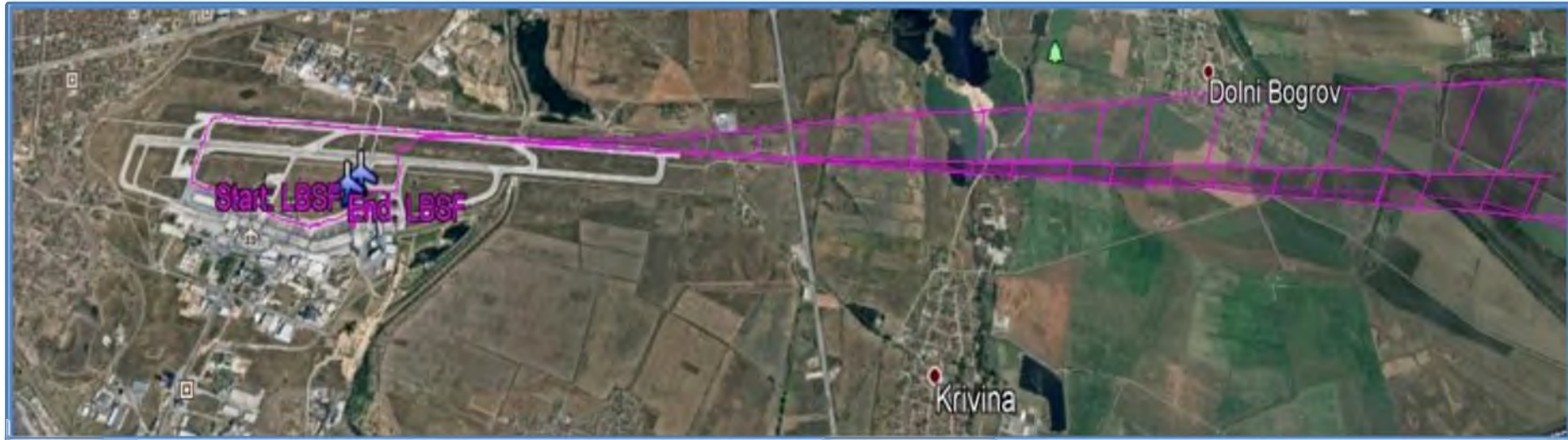

2. Aircraft information:

A/C	LZ-FBC
MSN	02540
Model	A320-214
Engine	CFM56-5B4/P

3. Recorder information

SSFDR	980-4700-042
FDIMU vend:	SAGEM
FDIMU P/N	ED48A100
SPN	360-04027-030
Words	psec:256



4. Recorder condition

Recorder not removed.

For transcript are used on-wing downloaded data from FDR and QAR.

5. Timing and Correlation

Timing on the transcript was established by FDR parameters.

CVR data not provided and correlating the CVR events to common events on the flight data recorder (FDR) not performed.

For time reference are used following recorded parameters:

Hours: UTC hours

Minutes: UTC Minutes

Seconds: UTC seconds

Relative Time: UTC

All times in Coordinated Universal Time (UTC)

6. Sequence of events

18:11:20 on 20.05.2021: Start ENG 1. GROUND RUN.

ENG 1 N1 19 %

ENG 2 N1 no record

ENG 1 N2 60 %

ENG 2 N2 no record



18:41:10 on 20.05.2021: STOP ENG 1. GROUND RUN completed.

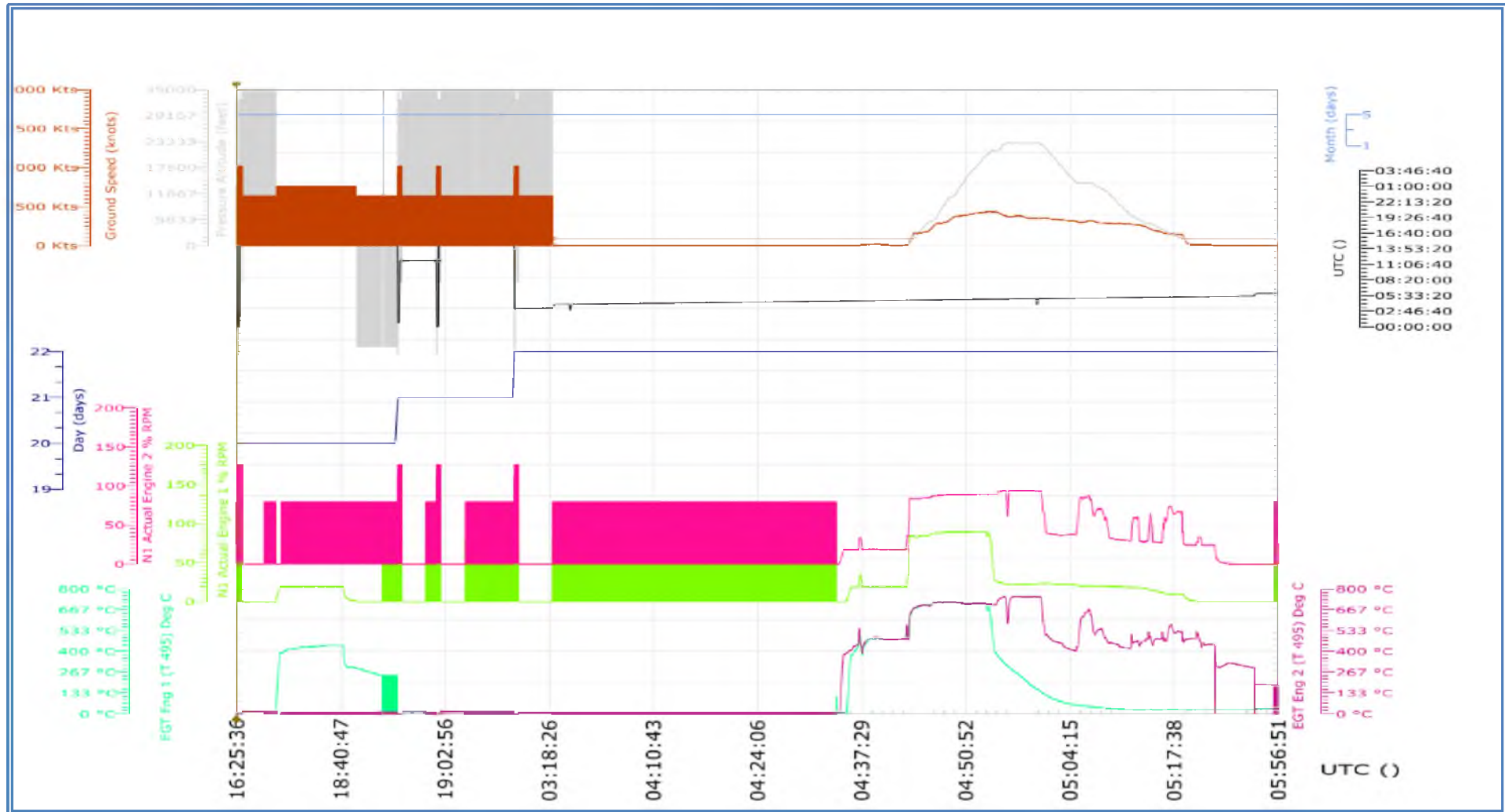



03:14:11 The record on FDR on aircraft LZ-FBC from date 22.05.2021 start.

04:34:44 Start of engine #2. Anomalies of engine parameters not observed.

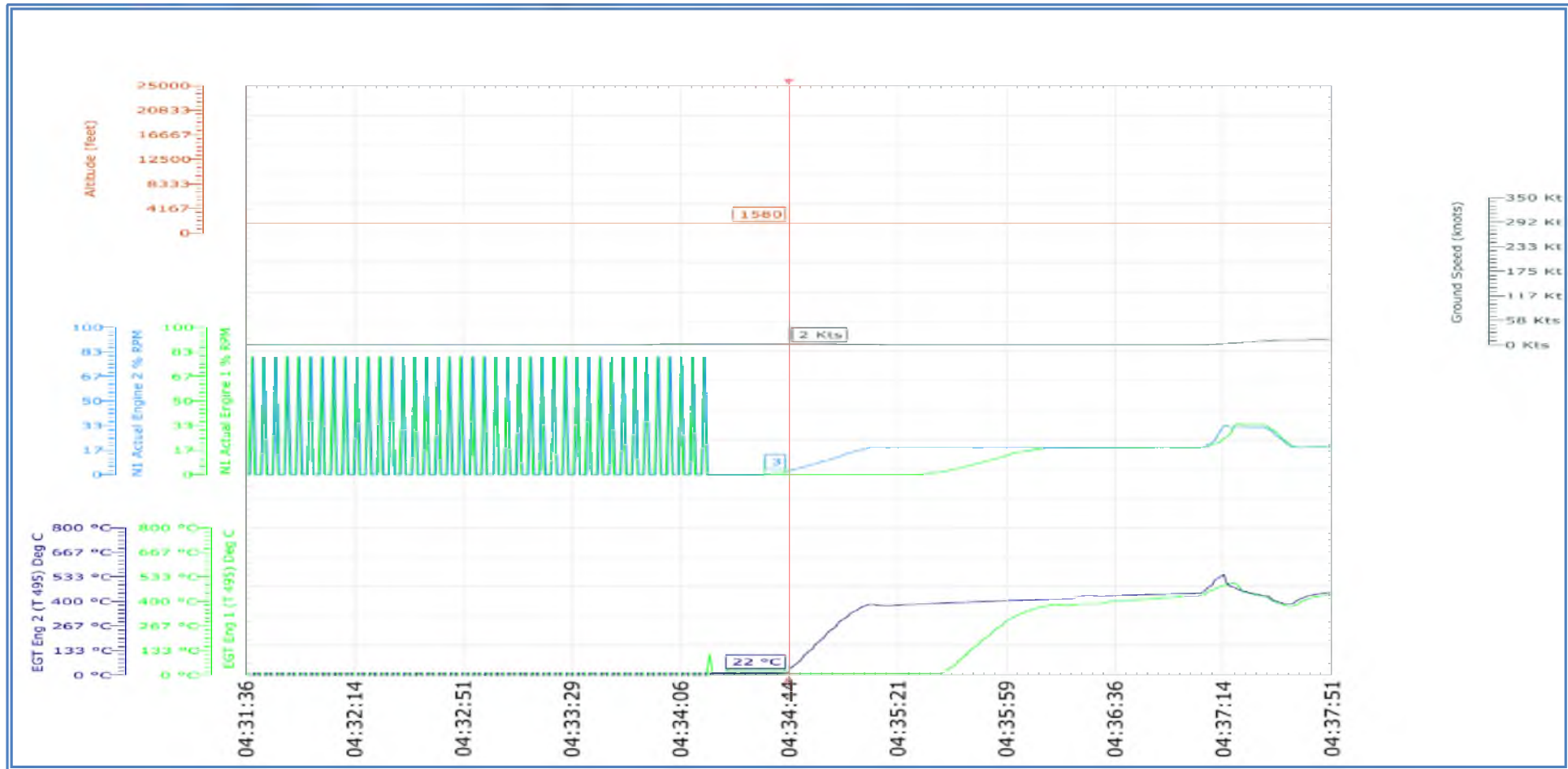



4:35:37 Start of engine #1. Anomalies of engine parameters not observed.

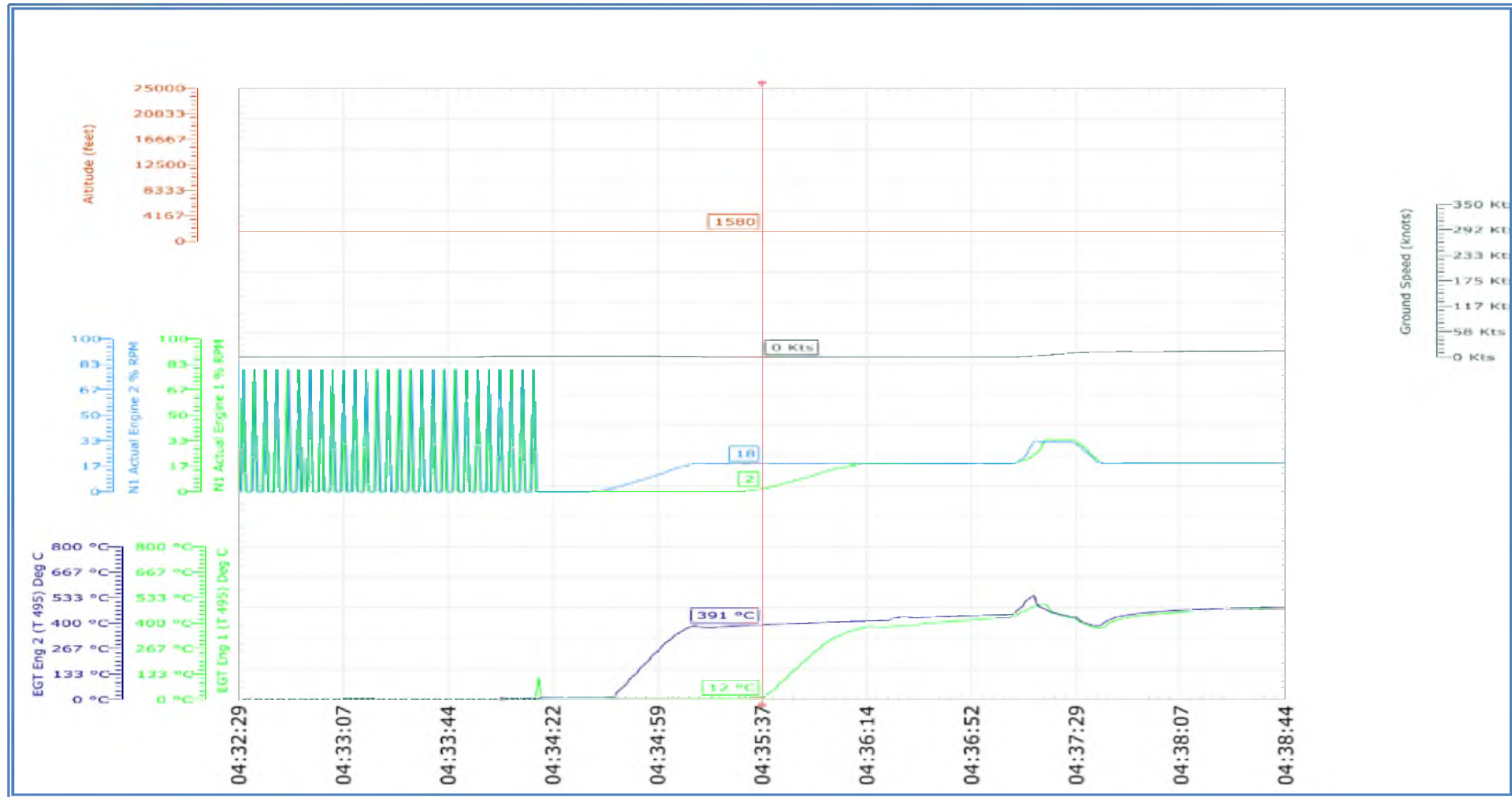

04:36:14 Both engines run.



Flight Data Recorder Factual Report
LZ-FBC-22052021_EN

Aero Technic BG

Sofia, Bulgaria 1540, Sofia Flight Training Ltd, office No8

E-mail: management@aerotechnic-bg.com

<https://www.aerotechnic-bg.com/>

ENG1

N1 18%

FUEL FLOW 857 PPH

EGT 379 deg. C

ENG2

N1 18%

FUEL FLOW 724 PPH

EGT 412 deg. C

FUEL QTY

L INNER 8576 Lbs

L OUTER 1408 Lbs

CENTRE 64 Lbs

R INNER 8832 Lbs

R OUTER 1536 Lbs



Flight Data Recorder Factual Report
LZ-FBC-22052021_EN

Aero Technic BG
 Sofia, Bulgaria 1540, Sofia Flight Training Ltd, office No8
 E-mail: management@aerotechnic-bg.com
<https://www.aerotechnic-bg.com/>

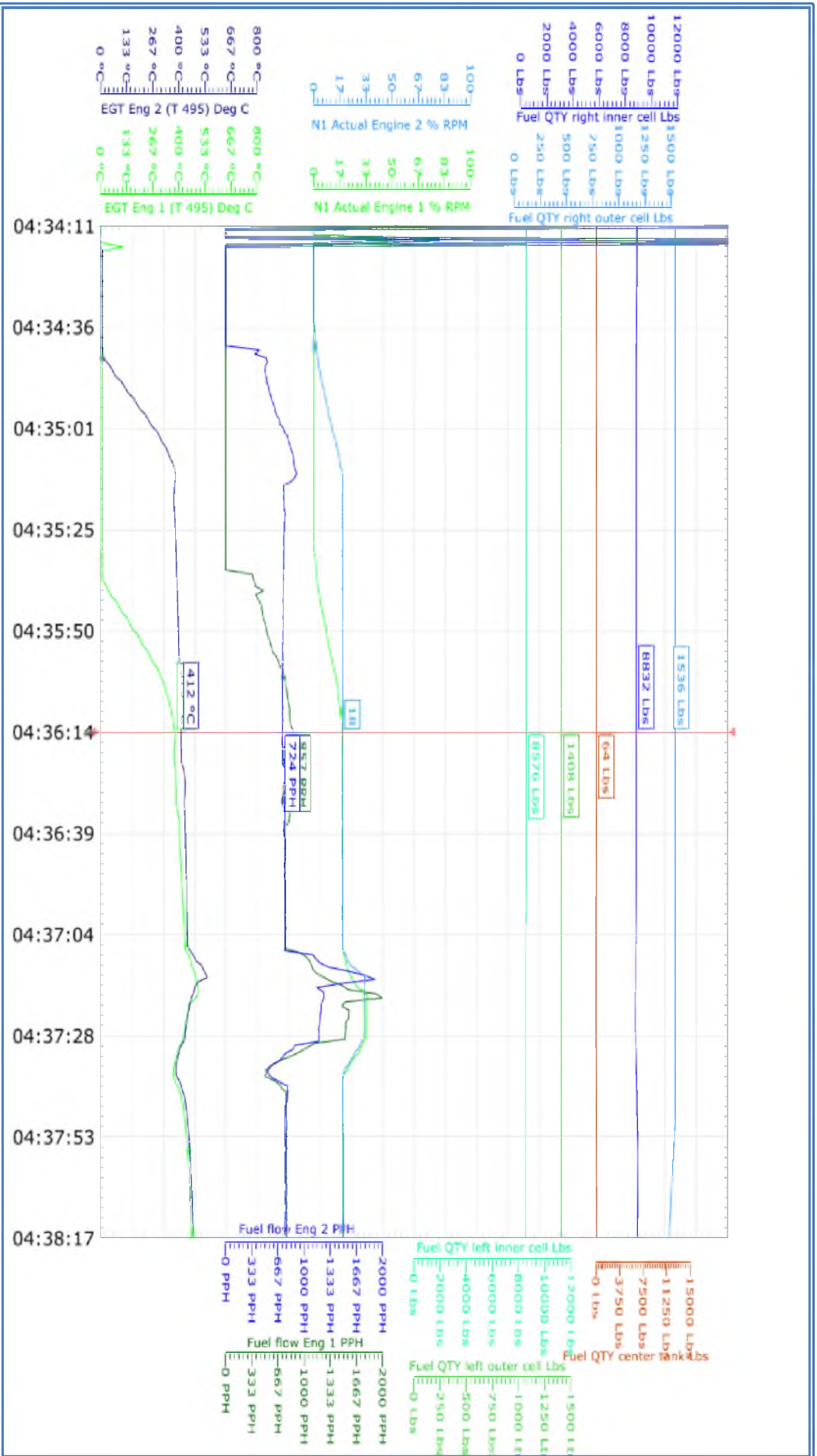



04:36:21 Cross Feed Valve in fully closed position

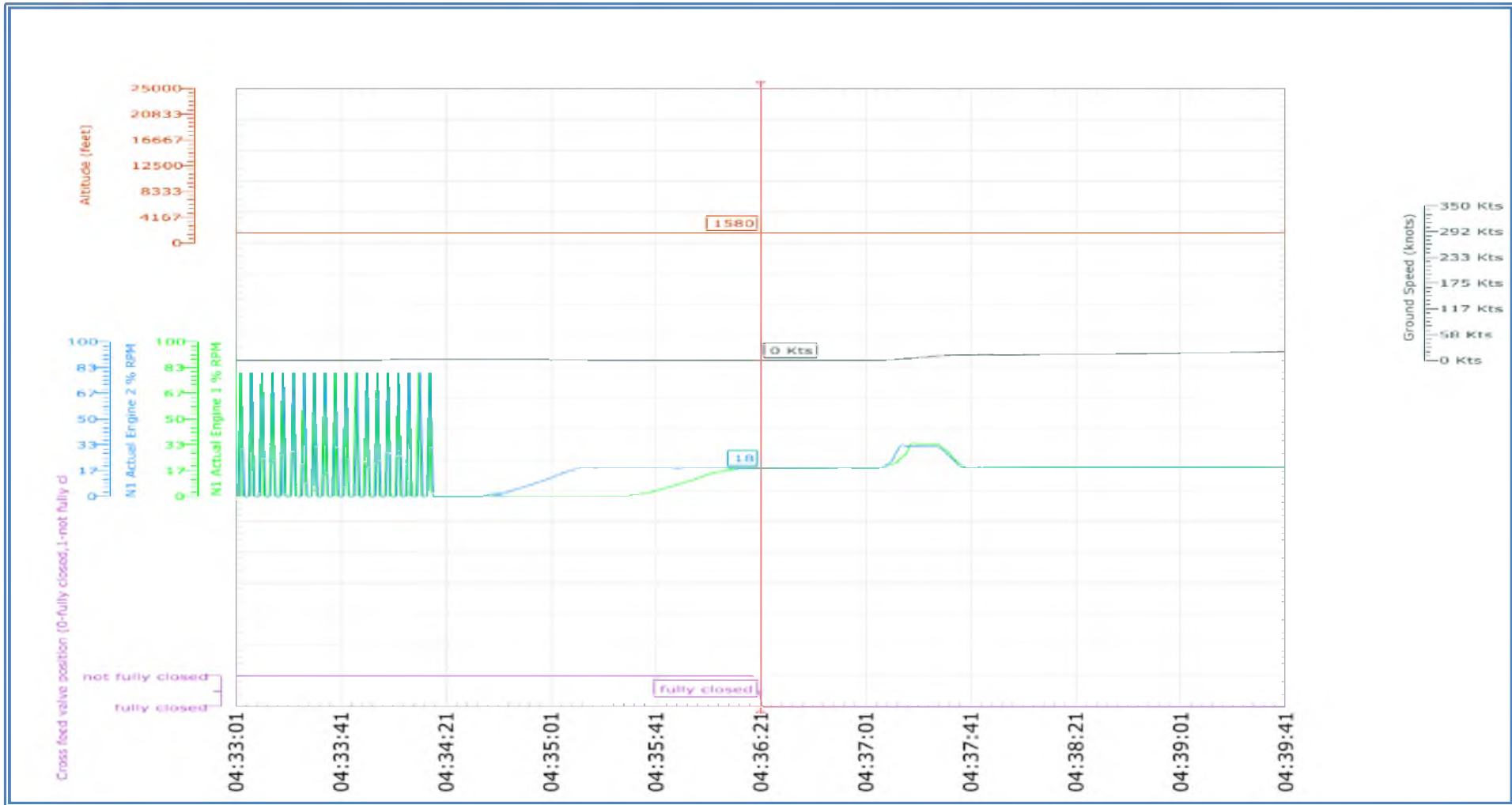

4:37:14 Taxi Out



Flight Data Recorder Factual Report
LZ-FBC-22052021_EN

Aero Technic BG
 Sofia, Bulgaria 1540, Sofia Flight Training Ltd, office No8
 E-mail: management@aerotechnic-bg.com
<https://www.aerotechnic-bg.com/>

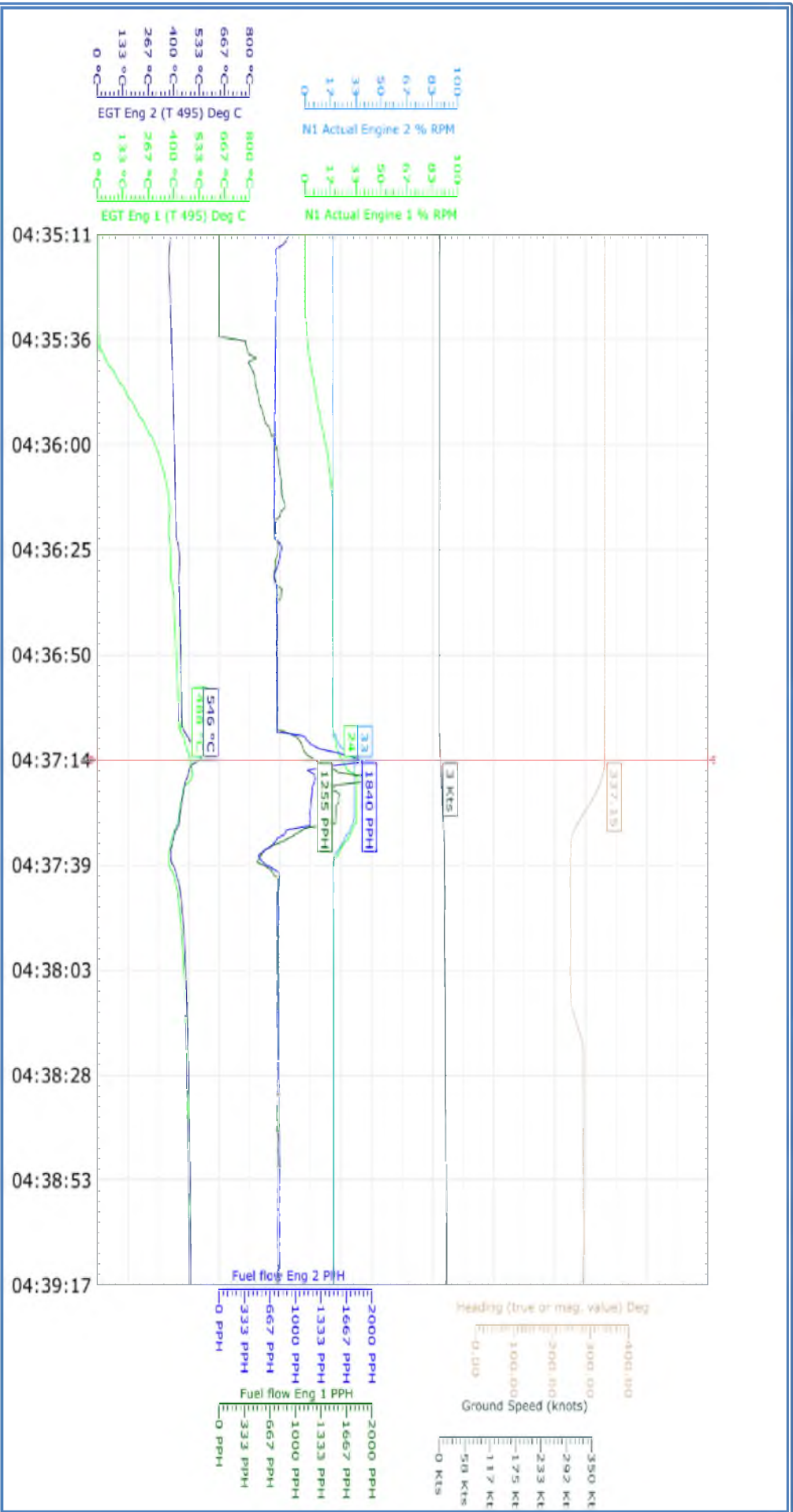



04:44:17 Take Off from Runway 09.

Gross Weight 144509 Lbs

ENG1

N1 84%

FUEL FLOW 9488 PPH

EGT 678 deg. C

ENG2

N1 84%

FUEL FLOW 7123 PPH

EGT 678 deg. C

FUEL QTY

L INNER 8385 Lbs

L OUTER 1408 Lbs

CENTRE 17 Lbs

R INNER 8704 Lbs

R OUTER 1408 Lbs



Flight Data Recorder Factual Report
LZ-FBC-22052021_EN

Aero Technic BG
 Sofia, Bulgaria 1540, Sofia Flight Training Ltd, office No8
 E-mail: management@aerotechnic-bg.com
<https://www.aerotechnic-bg.com/>

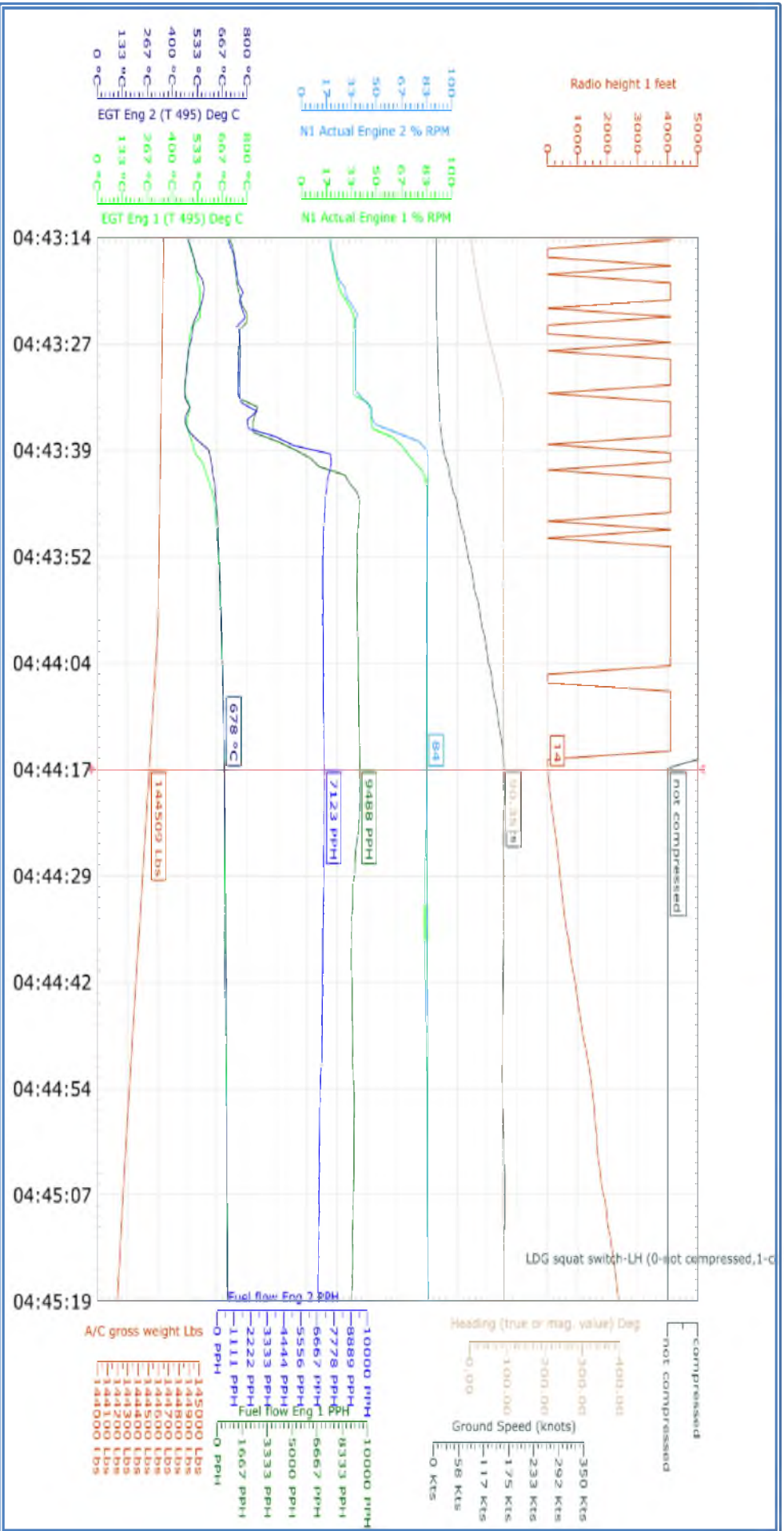



Flight Data Recorder Factual Report LZ-FBC-22052021_EN

Aero Technic BG
Sofia, Bulgaria 1540, Sofia Flight Training Ltd, office No8
E-mail: management@aerotechnic-bg.com
<https://www.aerotechnic-bg.com/>

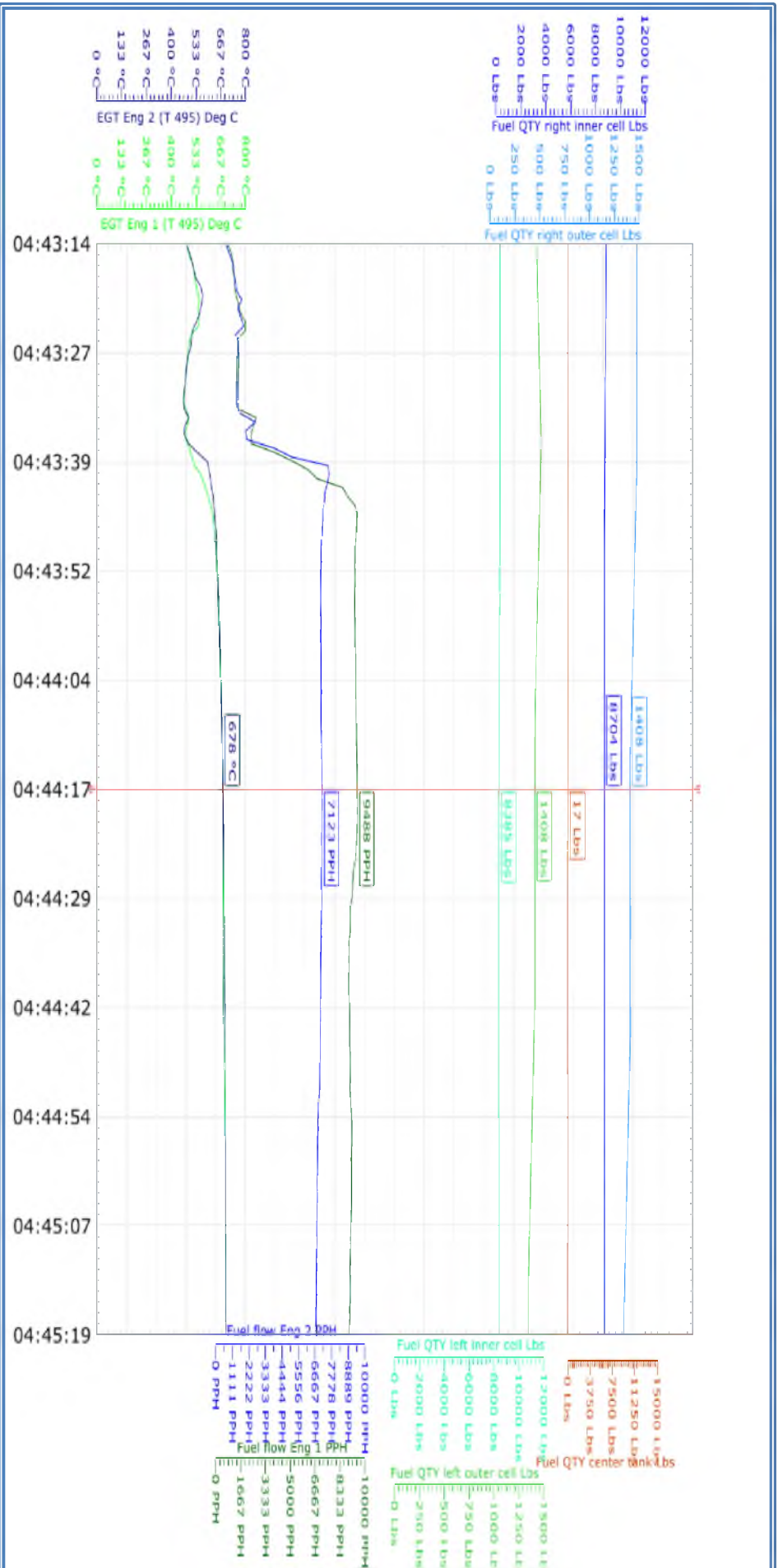





Flight Data Recorder Factual Report
LZ-FBC-22052021_EN

Aero Technic BG
Sofia, Bulgaria 1540, Sofia Flight Training Ltd, office No8
E-mail: management@aerotechnic-bg.com
<https://www.aerotechnic-bg.com/>

04:46:45 Autopilot (AP 2) activated.

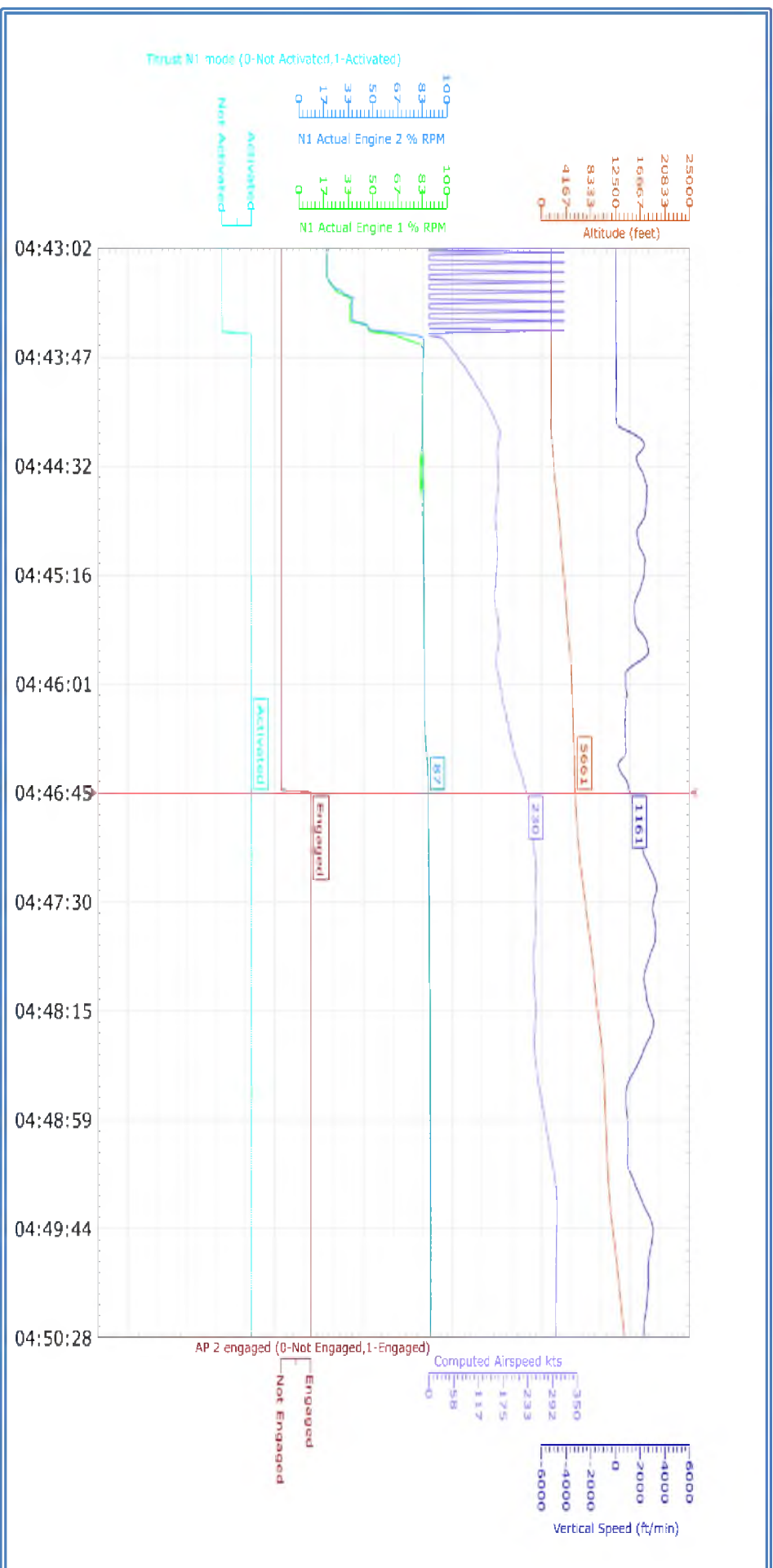



04:53:55 Engine 1, N1 speed drops down.

FUEL QTY:

L INNER 7104 Lbs
L OUTER 1408 Lbs
CENTRE 0 Lbs
R INNER 7808 Lbs
R OUTER 1472 Lbs

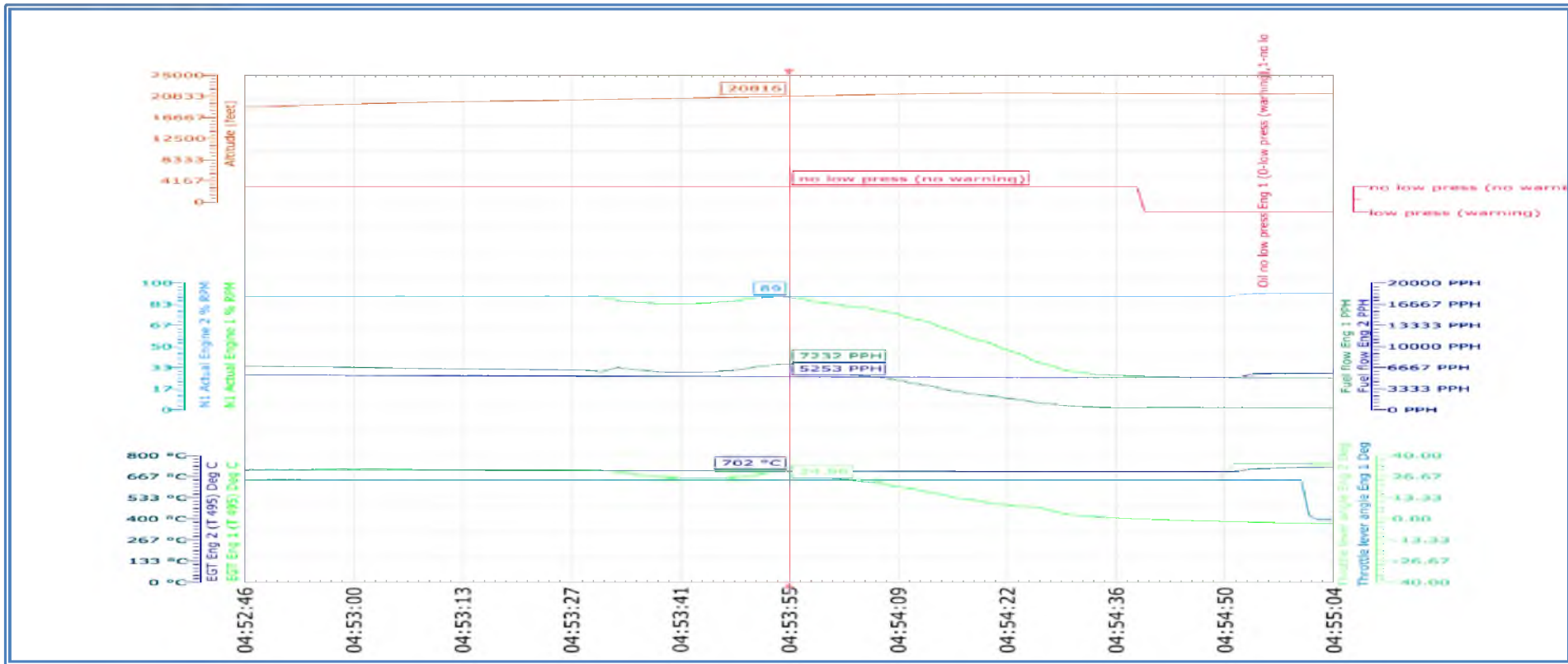



Flight Data Recorder Factual Report
LZ-FBC-22052021_EN

Aero Technic BG
 Sofia, Bulgaria 1540, Sofia Flight Training Ltd, office No8
 E-mail: management@aerotechnic-bg.com
<https://www.aerotechnic-bg.com/>

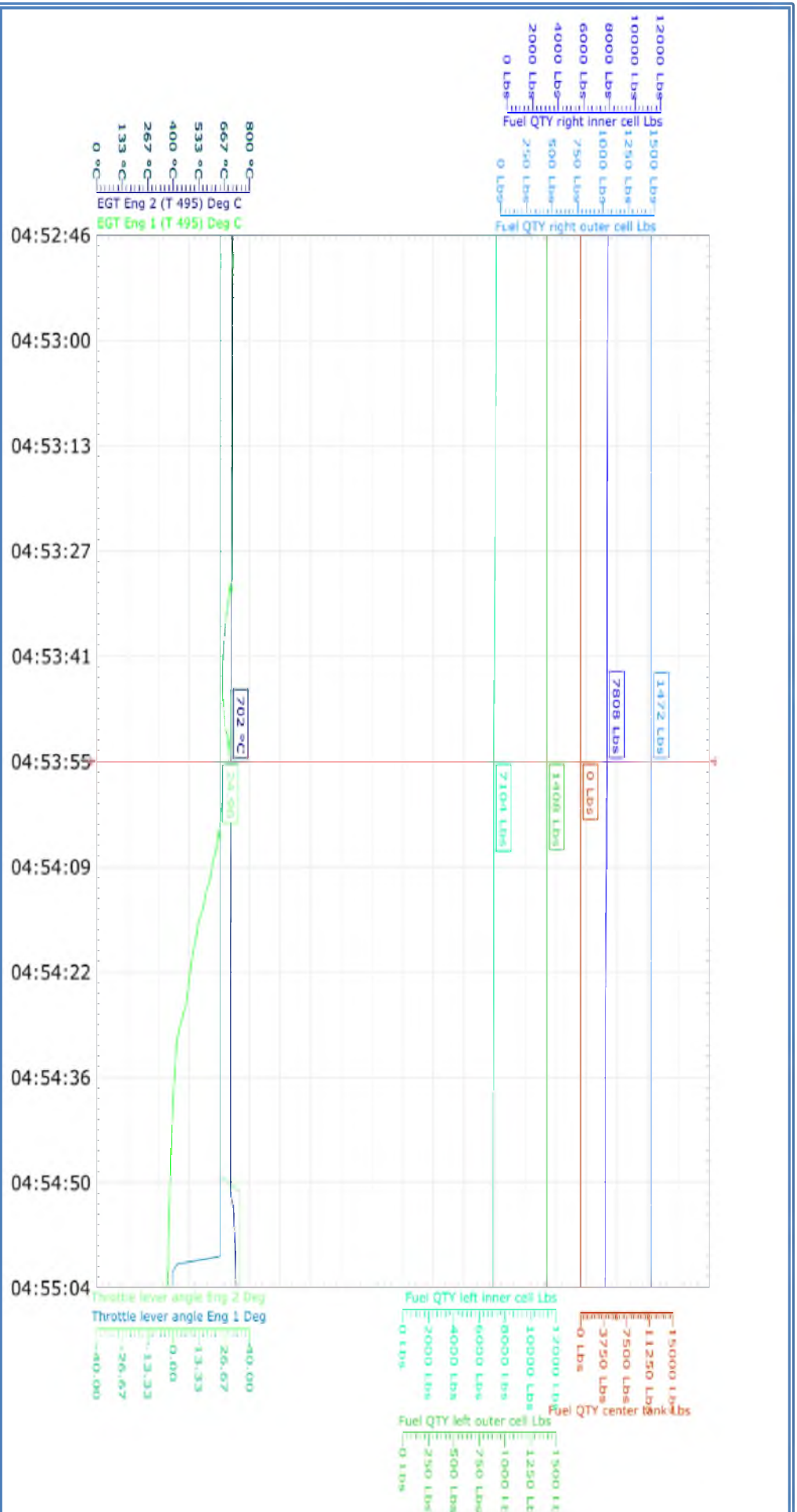



04:54:40 ENG 1 OIL LOW PRESSURE and Master Caution alarms

ENG1

N1 27 %
FUEL FLOW 356 PPH
EGT 399 deg. C

ENG2

N1 89 %
FUEL FLOW 5152 PPH
EGT 699 deg. C
Vertical Speed -412 ft/min

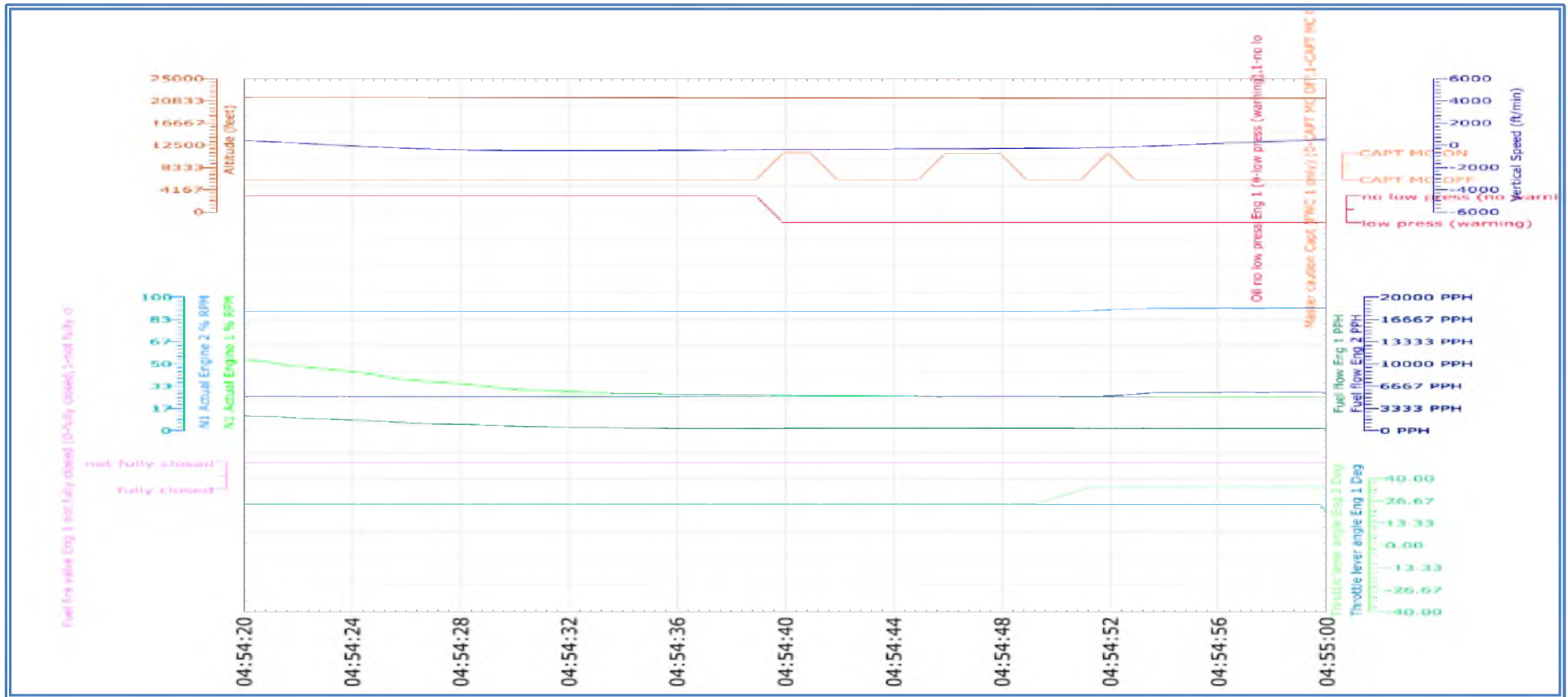



Flight Data Recorder Factual Report
LZ-FBC-22052021_EN

Aero Technic BG
Sofia, Bulgaria 1540, Sofia Flight Training Ltd, office No8
E-mail: management@aerotechnic-bg.com
<https://www.aerotechnic-bg.com/>

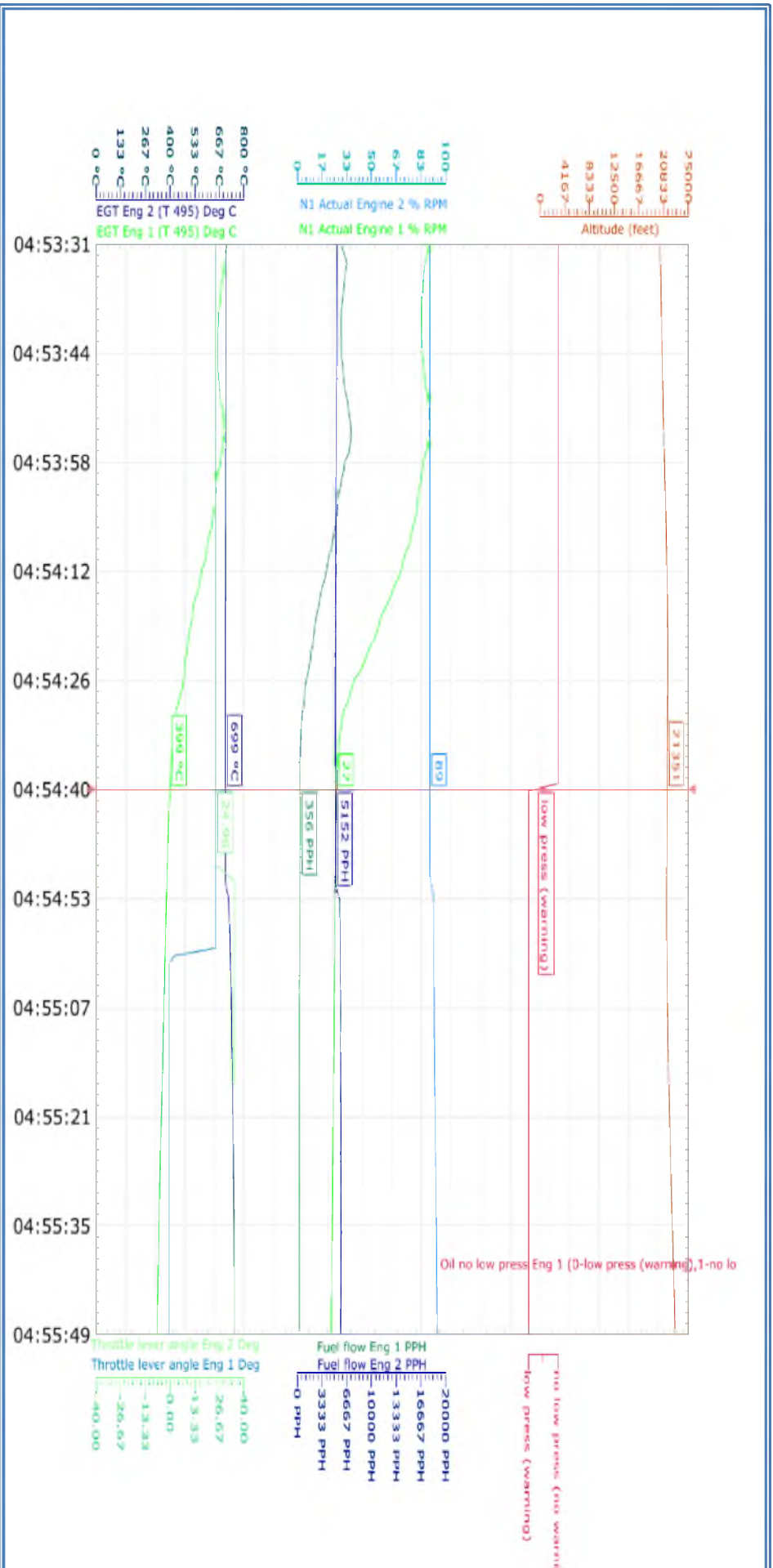



Flight Data Recorder Factual Report
LZ-FBC-22052021_EN

Aero Technic BG
Sofia, Bulgaria 1540, Sofia Flight Training Ltd, office No8
E-mail: management@aerotechnic-bg.com
<https://www.aerotechnic-bg.com/>

04:54:52 Throttle Lever Angle ENGINE 2 moved from 24.6 deg. To 34.8 deg.
ENG 2 NI 90 %.

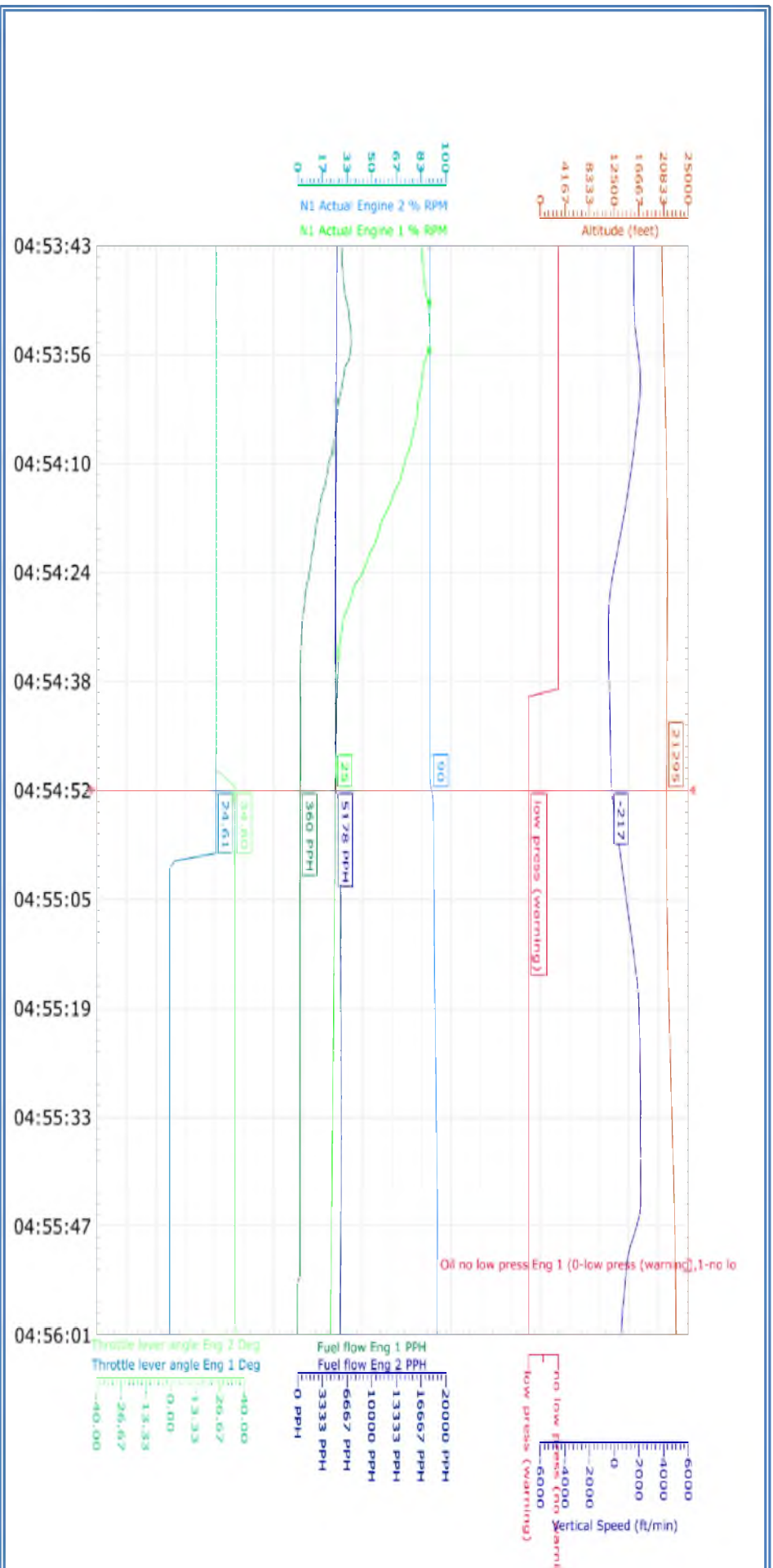



Flight Data Recorder Factual Report
LZ-FBC-22052021_EN

Aero Technic BG
 Sofia, Bulgaria 1540, Sofia Flight Training Ltd, office No8
 E-mail: management@aerotechnic-bg.com
<https://www.aerotechnic-bg.com/>

04:55:02 Throttle Lever Angle, Engine 1, Set to 0 degrees.

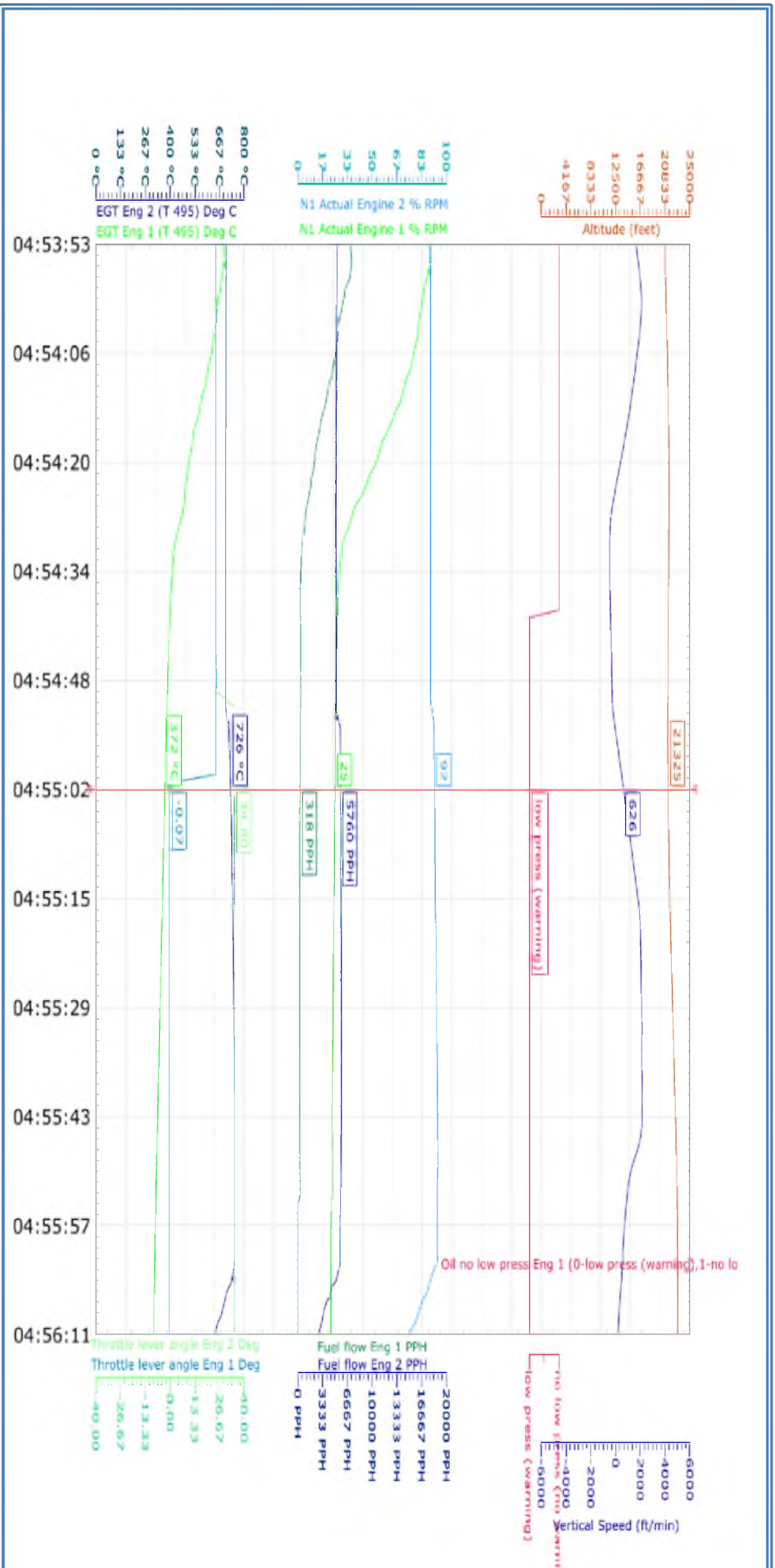

04:55:54 Fire Valve Engine 1 set to Fully Closed position. Master Caution alarm.

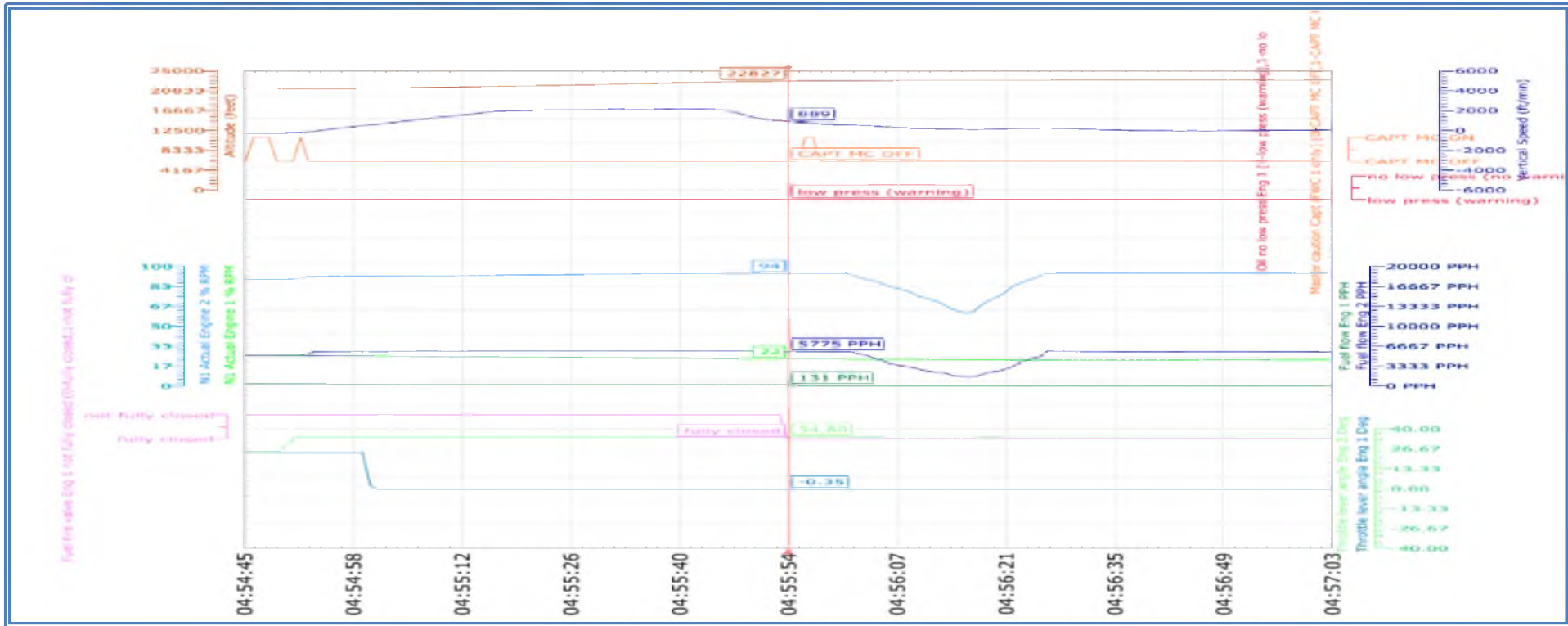



Flight Data Recorder Factual Report
LZ-FBC-22052021_EN

Aero Technic BG
 Sofia, Bulgaria 1540, Sofia Flight Training Ltd, office No8
 E-mail: management@aerotechnic-bg.com
<https://www.aerotechnic-bg.com/>

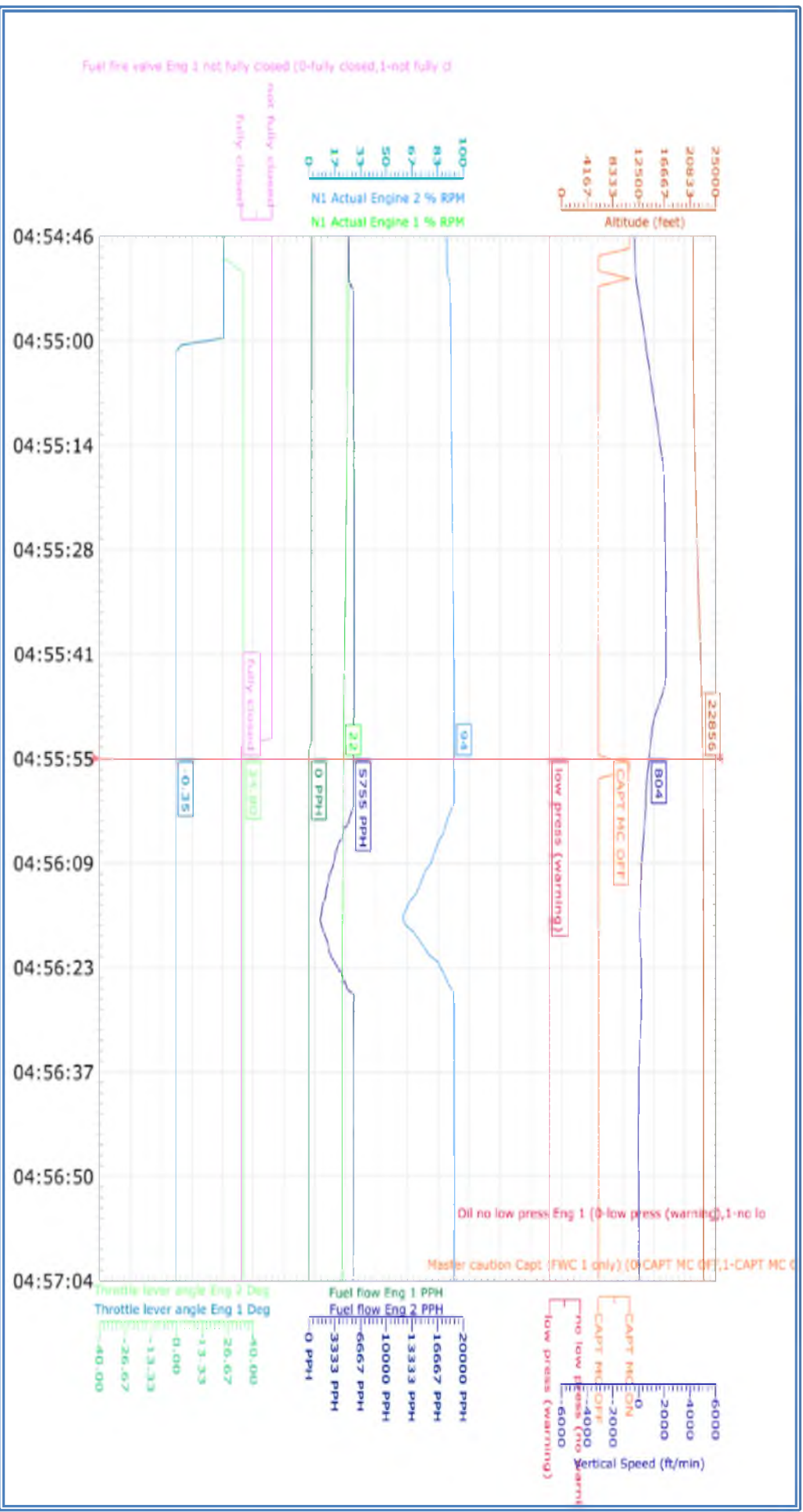

04:55:55 Master Caution signal for 3 seconds.



Flight Data Recorder Factual Report
LZ-FBC-22052021_EN

Aero Technic BG
 Sofia, Bulgaria 1540, Sofia Flight Training Ltd, office No8
 E-mail: management@aerotechnic-bg.com
<https://www.aerotechnic-bg.com/>

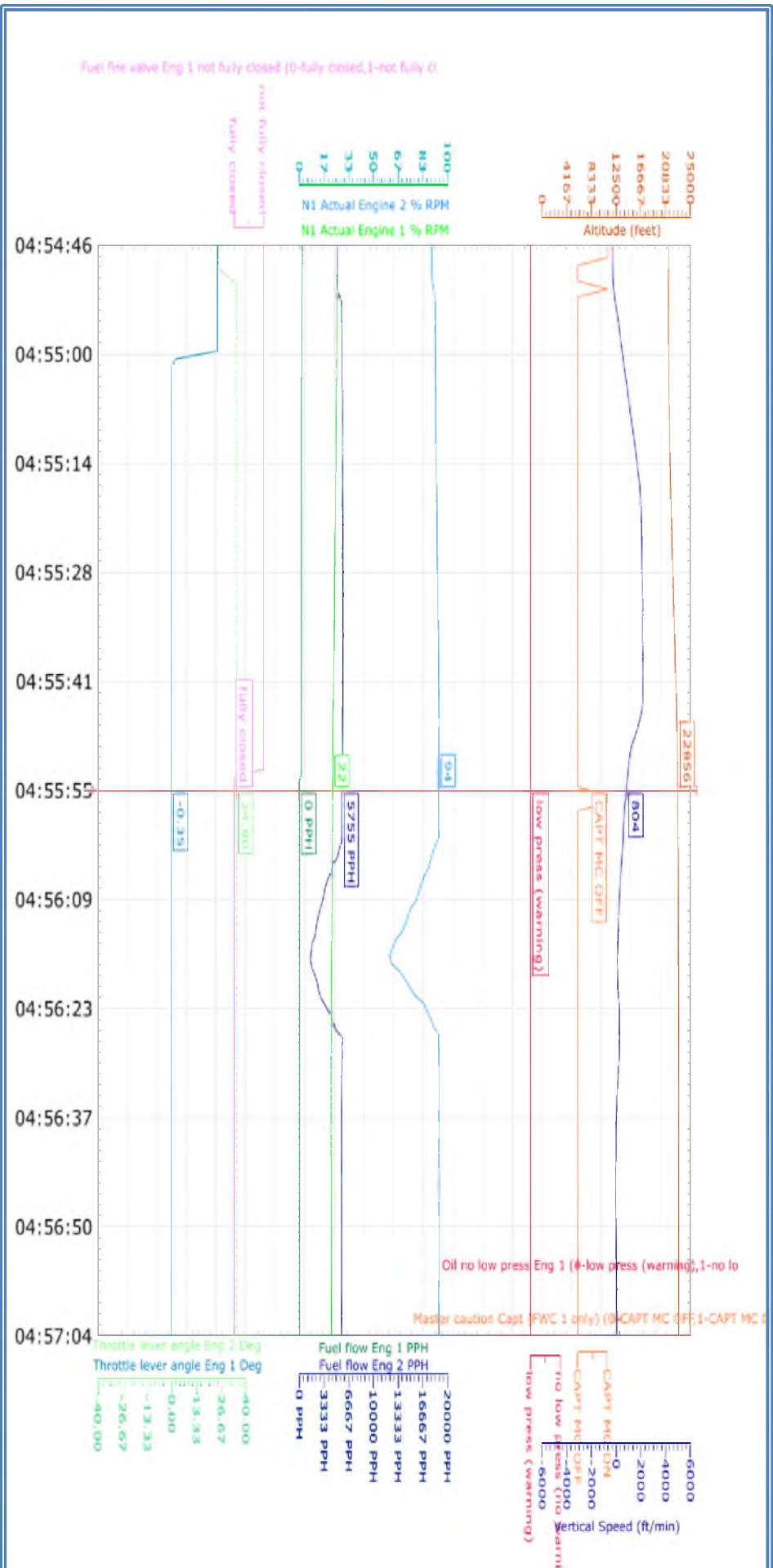

04:56:17 Engine 2 thrust reduced for 5-10 seconds.



Active AP modes
ATS Speed Mach Mode
H/PATH sub mode NAV

ENG1

N1 16%
FUEL FLOW 0 PPH
EGT 308 deg. C

ENG2

N1 62 %
FUEL FLOW 1492 PPH
EGT 578 deg. C
Vertical Speed 64 ft/min

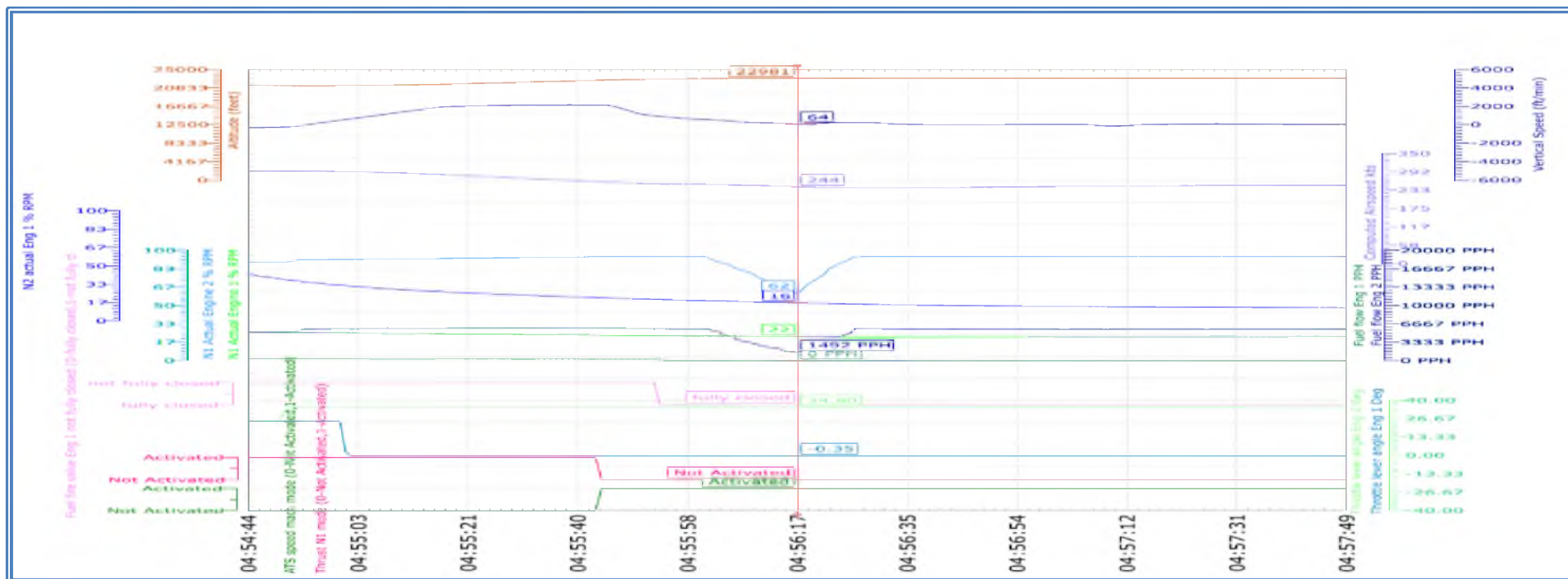

04:56:51 VHF1 emitting



Flight Data Recorder Factual Report
LZ-FBC-22052021_EN

Aero Technic BG
 Sofia, Bulgaria 1540, Sofia Flight Training Ltd, office No8
 E-mail: management@aerotechnic-bg.com
<https://www.aerotechnic-bg.com/>

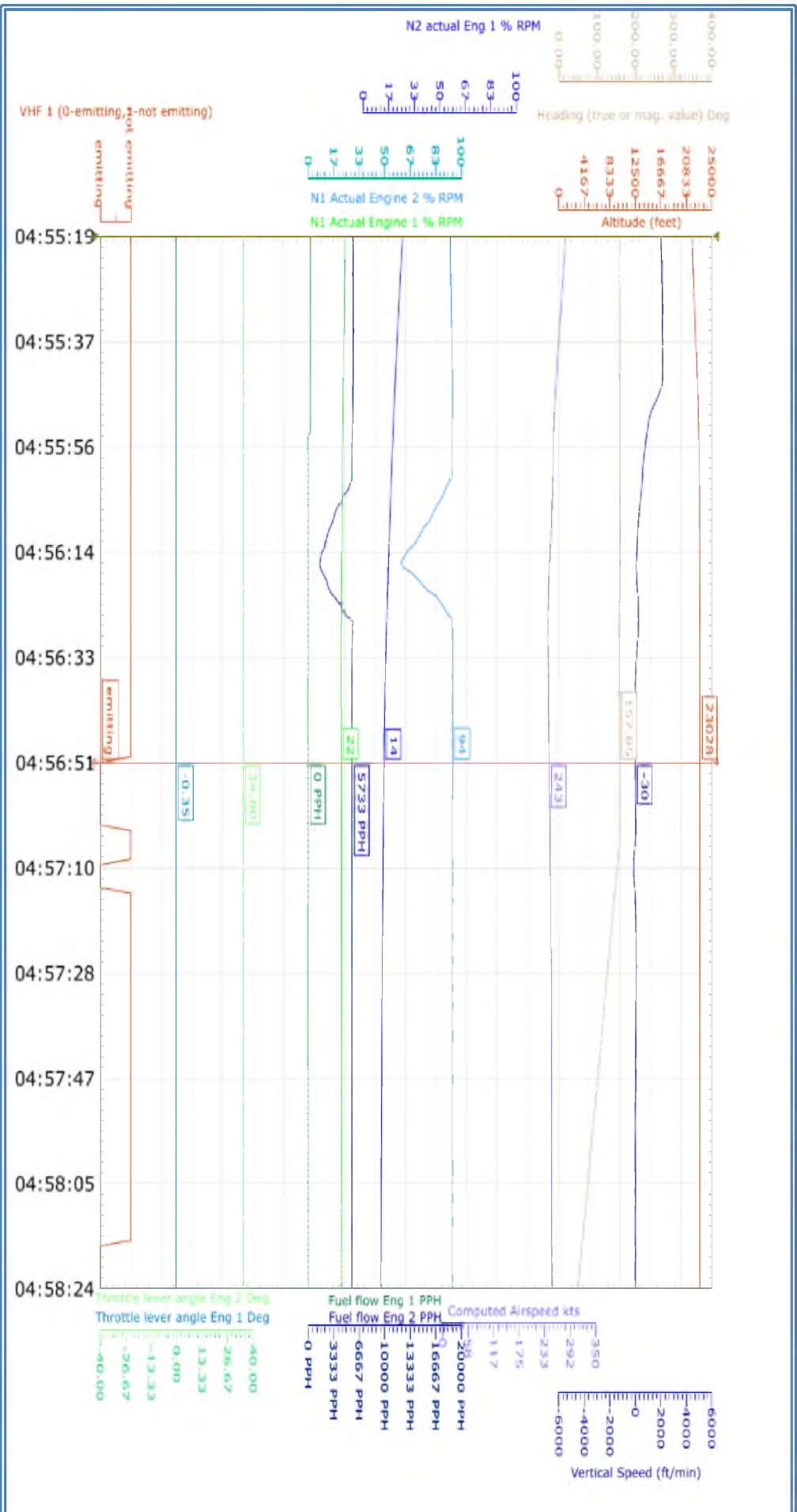



04:57:05 MAG HEADING starts change from 157 deg to 330 deg.

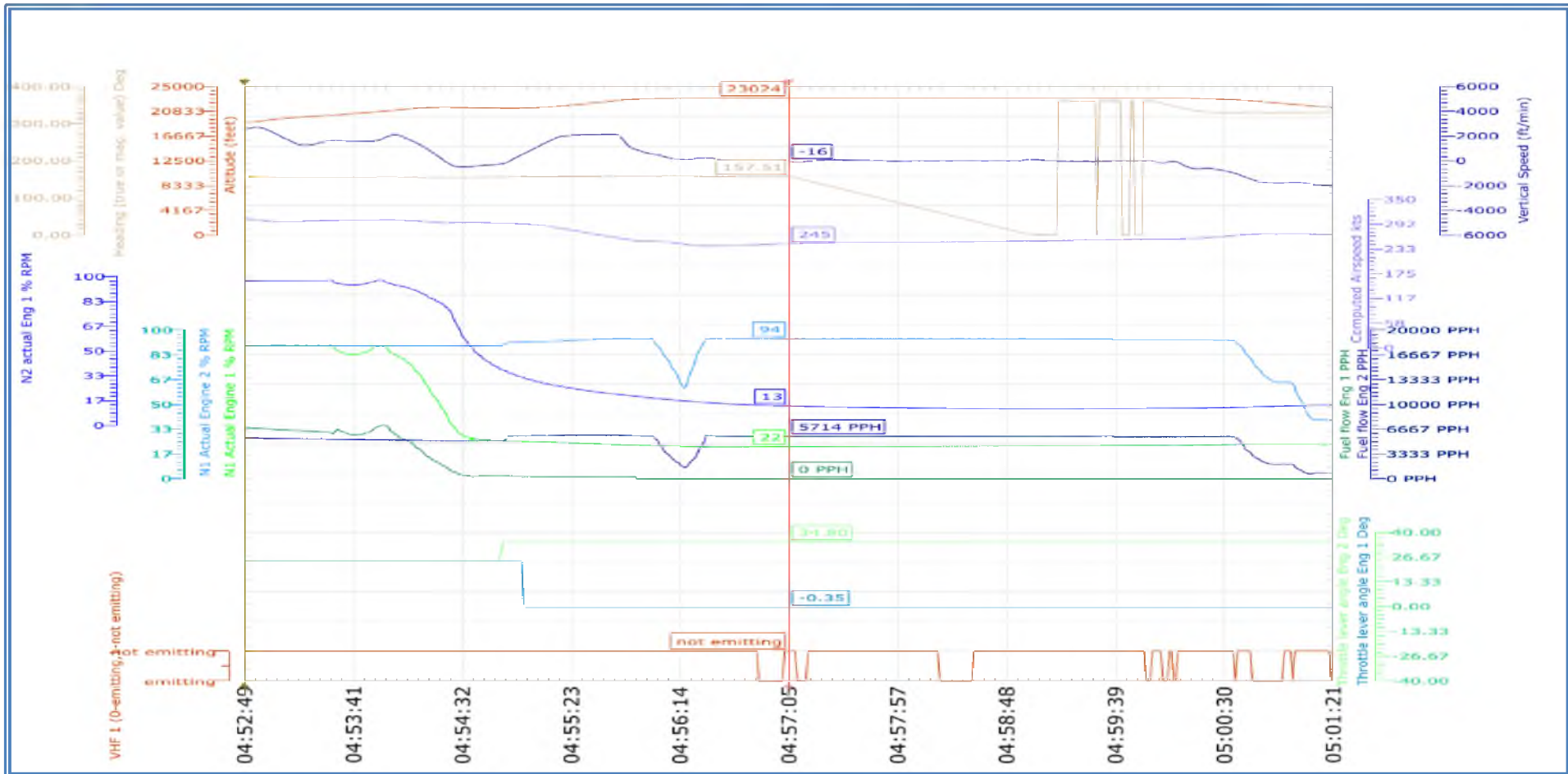



Flight Data Recorder Factual Report
LZ-FBC-22052021_EN

Aero Technic BG
Sofia, Bulgaria 1540, Sofia Flight Training Ltd, office No8
E-mail: management@aerotechnic-bg.com
<https://www.aerotechnic-bg.com/>

04:59:34 Cross Feed Valve NOT Fully Closed position

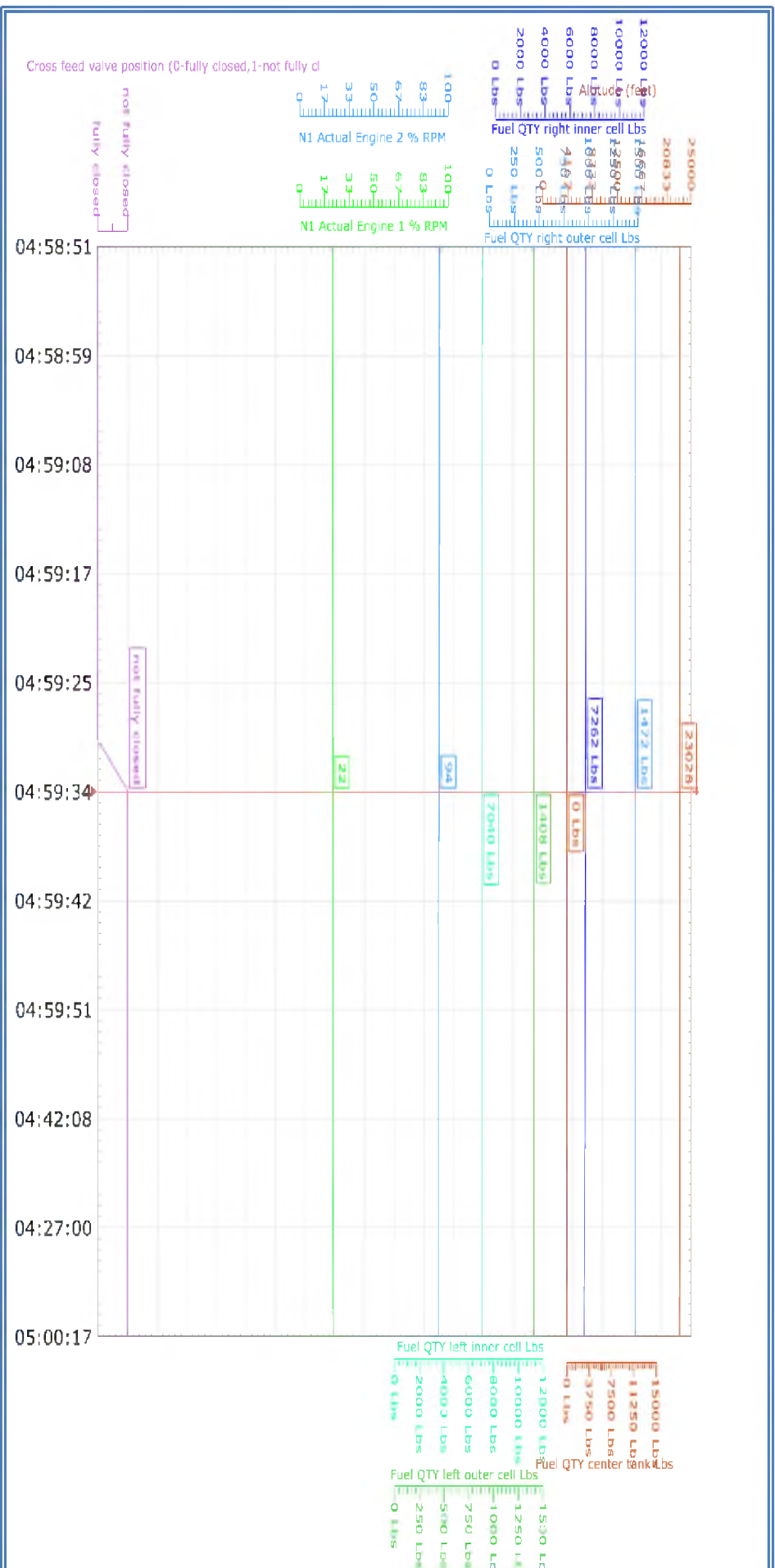



05:00:35 Starts to descent

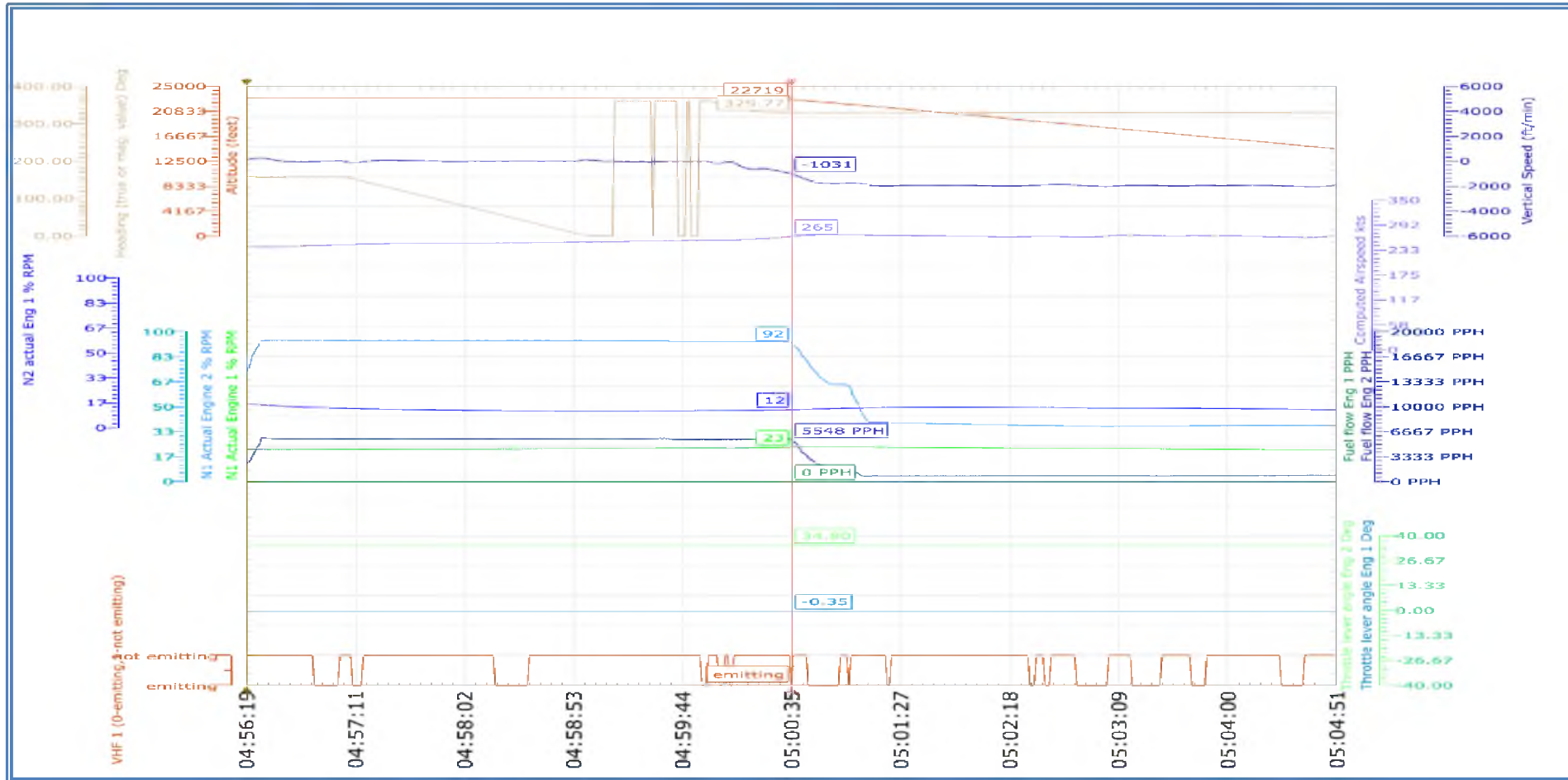



05:05:32 Turns to HDG 084 deg.
Computed Airspeed, CAS: 252 kts.
Vertical Speed, VS: -33 ft/min
Altitude 14016 ft

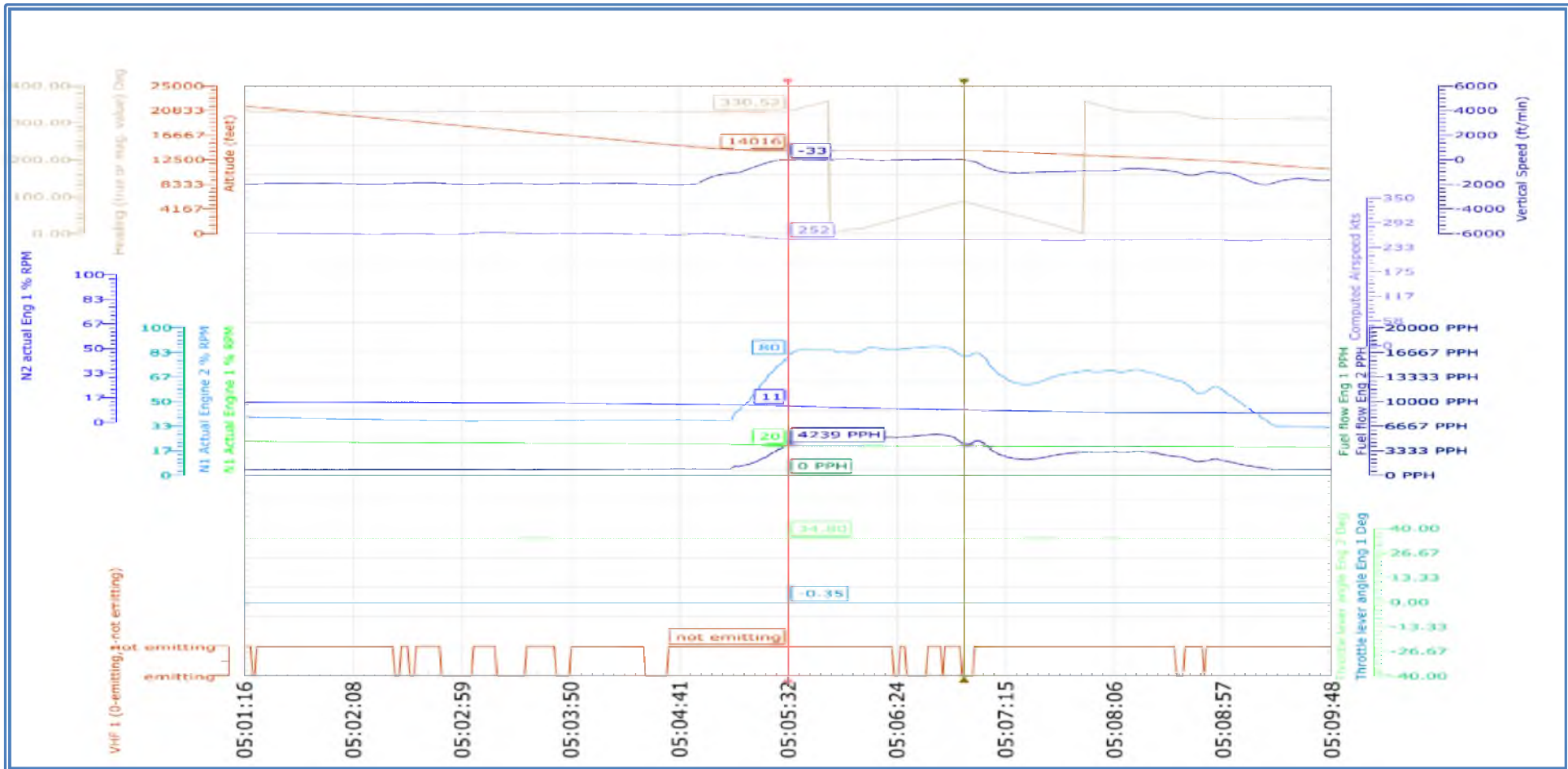



05:06:55 Turns to HDG 310 deg.
Computed Airspeed, CAS: 251 kts.
Vertical Speed, VS: 8 ft/min
Altitude 14024 ft

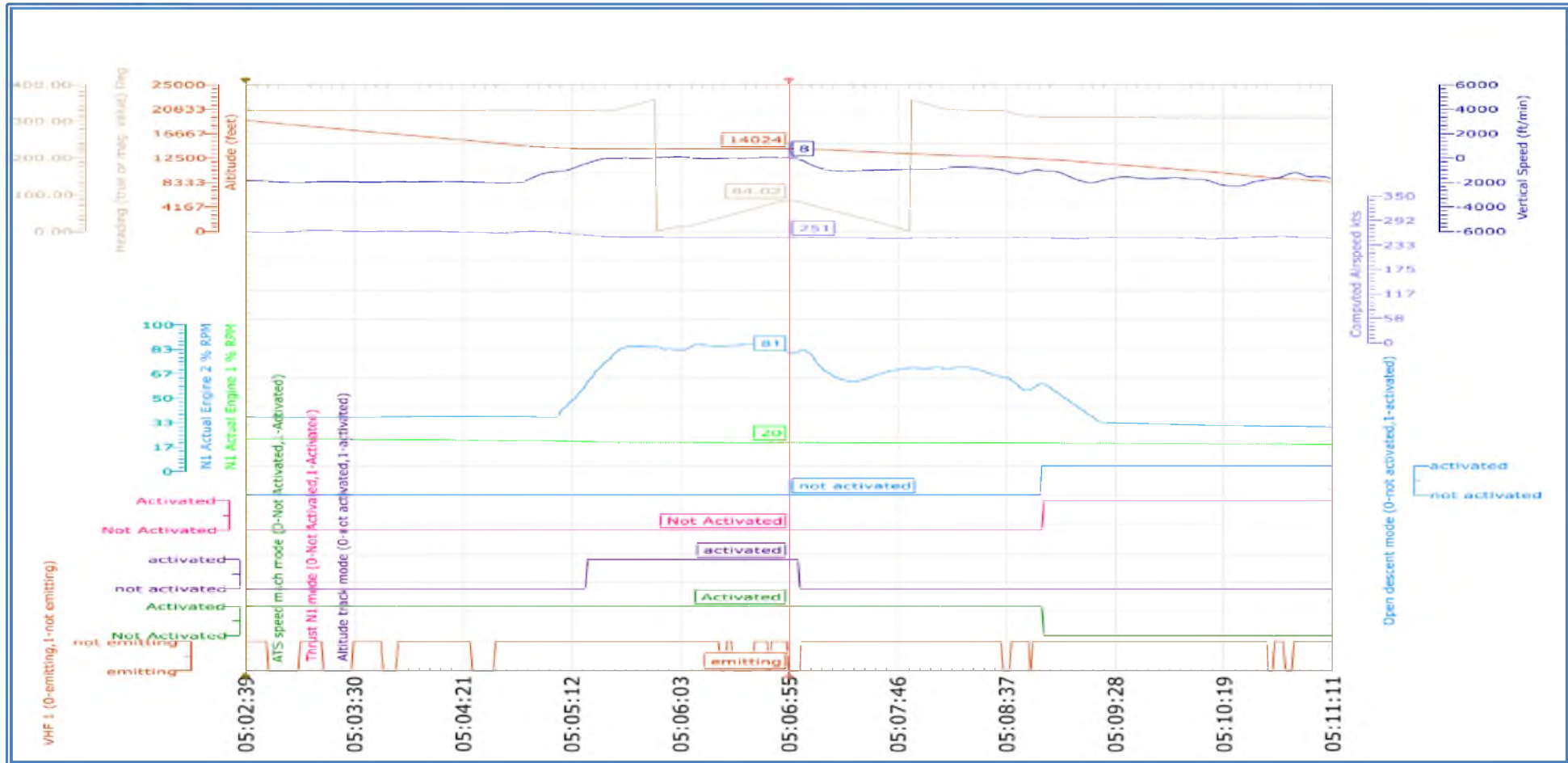



Flight Data Recorder Factual Report
LZ-FBC-22052021_EN

Aero Technic BG
Sofia, Bulgaria 1540, Sofia Flight Training Ltd, office No8
E-mail: management@aerotechnic-bg.com
<https://www.aerotechnic-bg.com/>

05:13:44 Turns to HDG 270 deg.
Computed Airspeed, CAS: 229 kts.
Vertical Speed, VS: -928 ft/min
Altitude 5300 ft

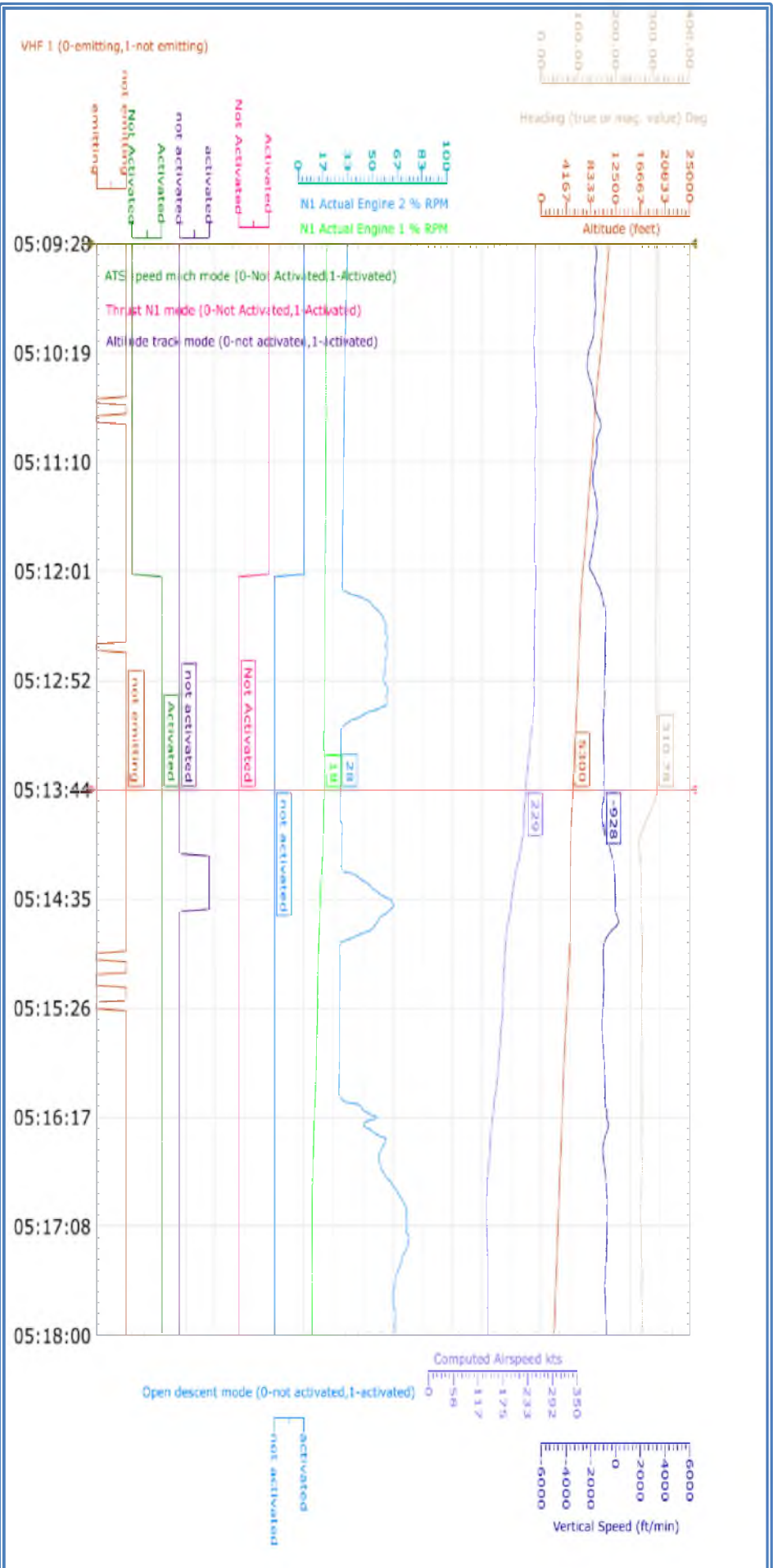



05:14:11 SLATS 18
Computed Airspeed, CAS: 217 kts.
Vertical Speed, VS: -447 ft/min
Altitude 4868 ft

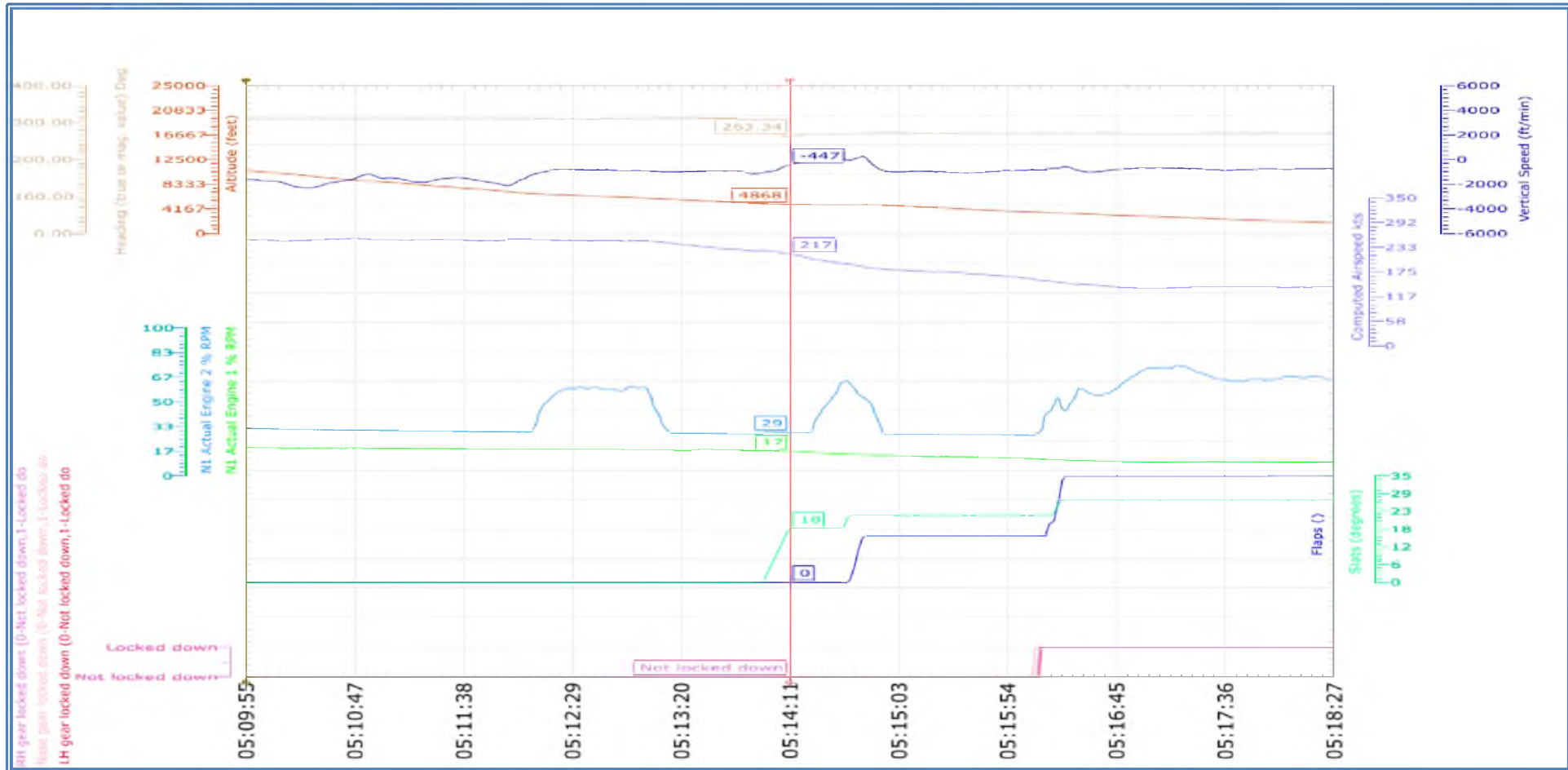



05:14:46 FLAPS 15, SLATS 22
Computed Airspeed, CAS: 186 kts.
Vertical Speed, VS: 202 ft/min
Altitude 4832 ft

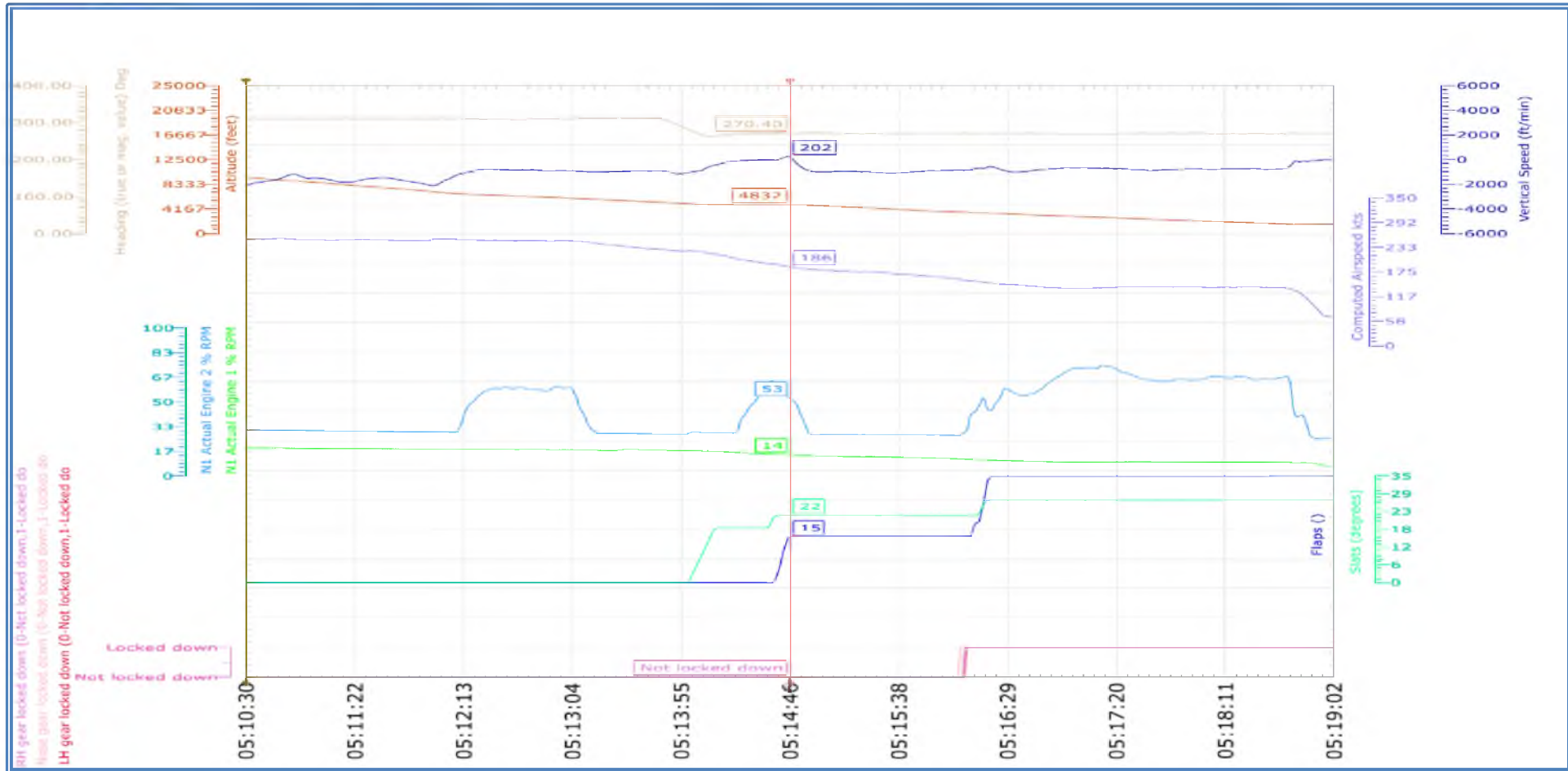



05:16:10 All Gears Locked Down
Computed Airspeed, CAS: 254 kts.
Vertical Speed, VS: -864 ft/min
Altitude 3557 ft

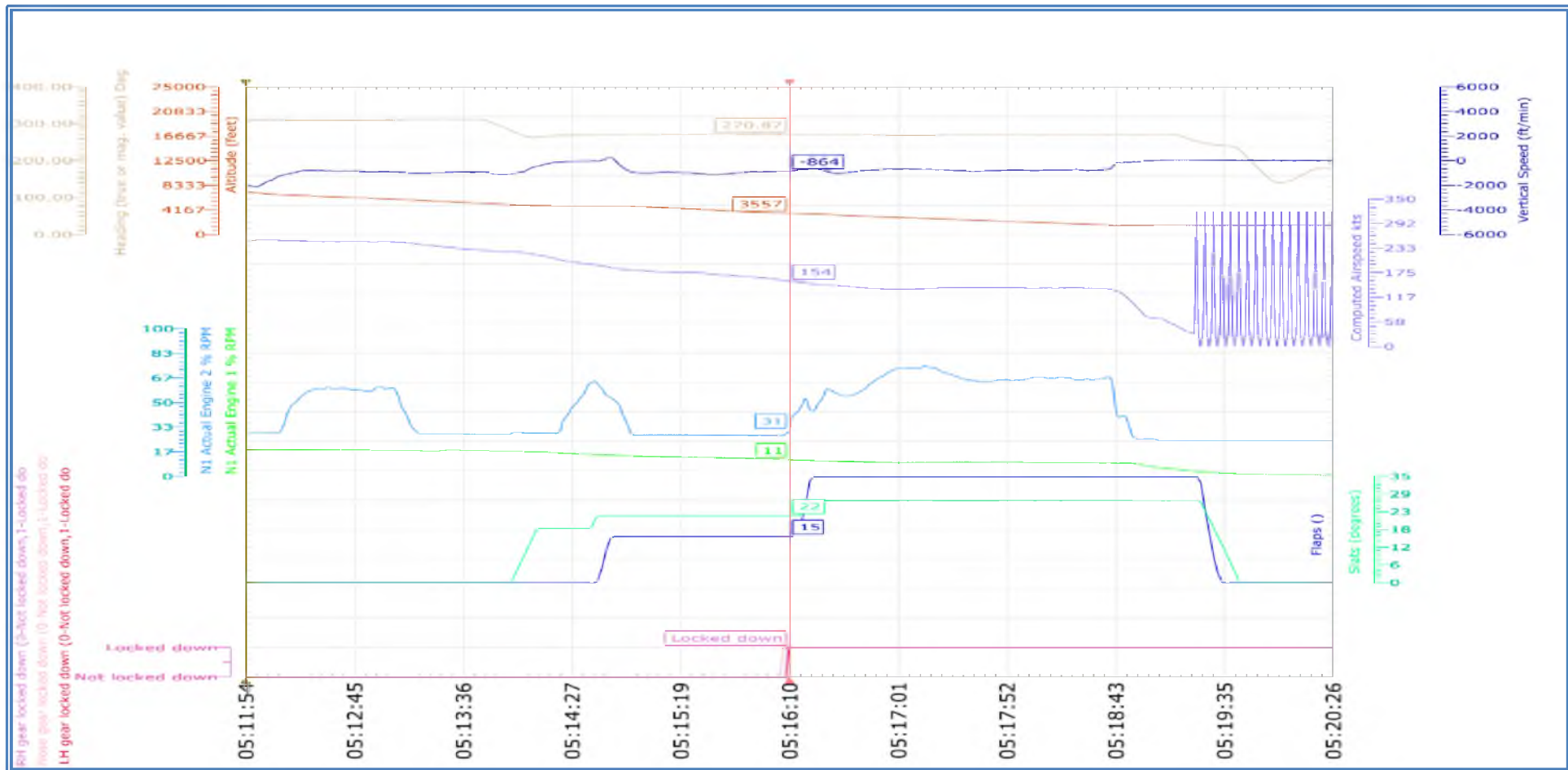



05:16:22 FLAPS 35, SLATS 27
Computed Airspeed, CAS: 148 kts.
Vertical Speed, VS: -629 ft/min
Altitude 3404 ft

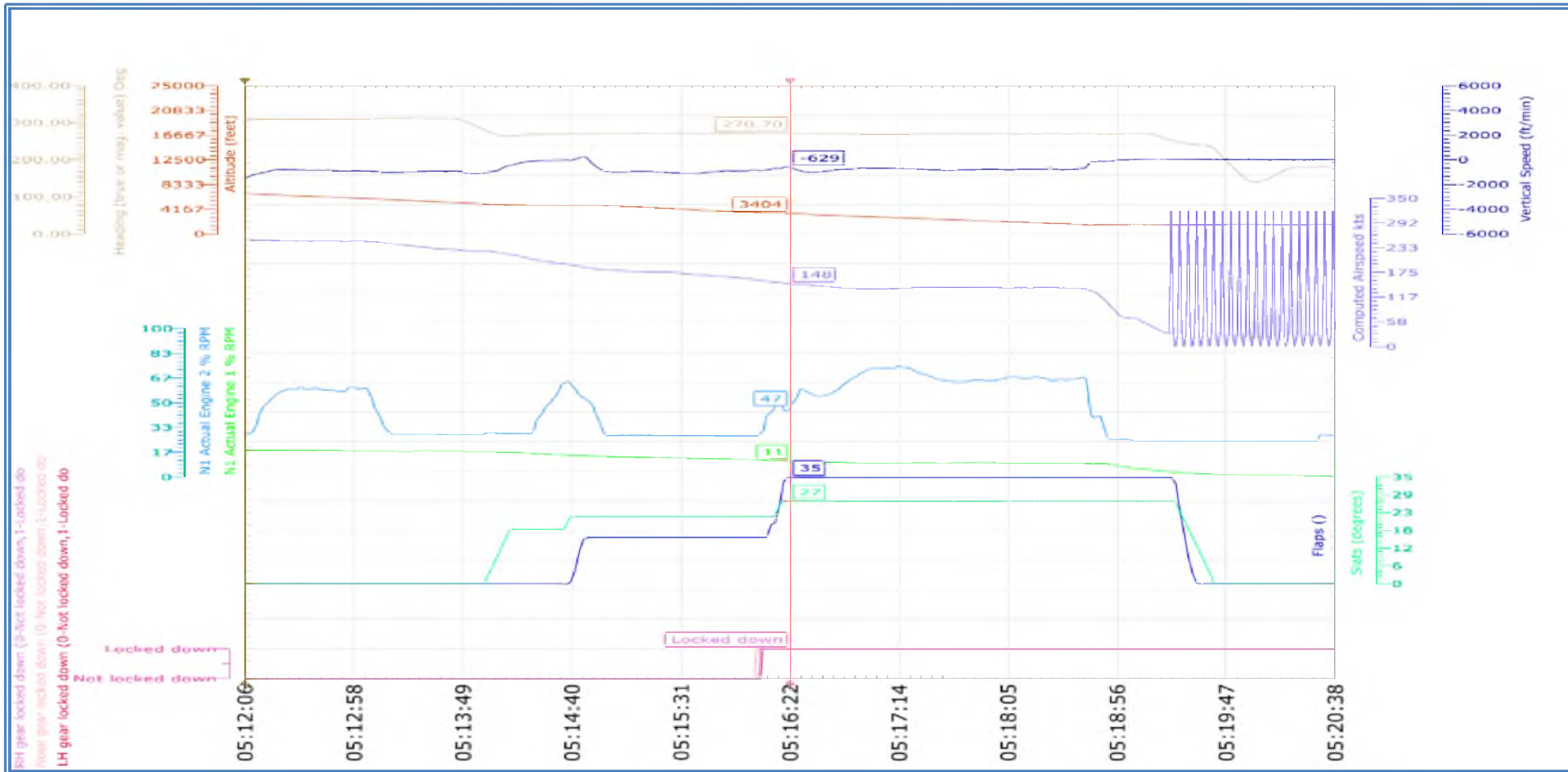



Flight Data Recorder Factual Report

LZ-FBC-22052021_EN

Aero Technic BG
Sofia, Bulgaria 1540, Sofia Flight Training Ltd, office No8
E-mail: management@aerotechnic-bg.com
<https://www.aerotechnic-bg.com/>

05:18:42 Touch Down at SOF Airport
FLAPS 35, SLATS 27
Gross Weight 135659 Lb

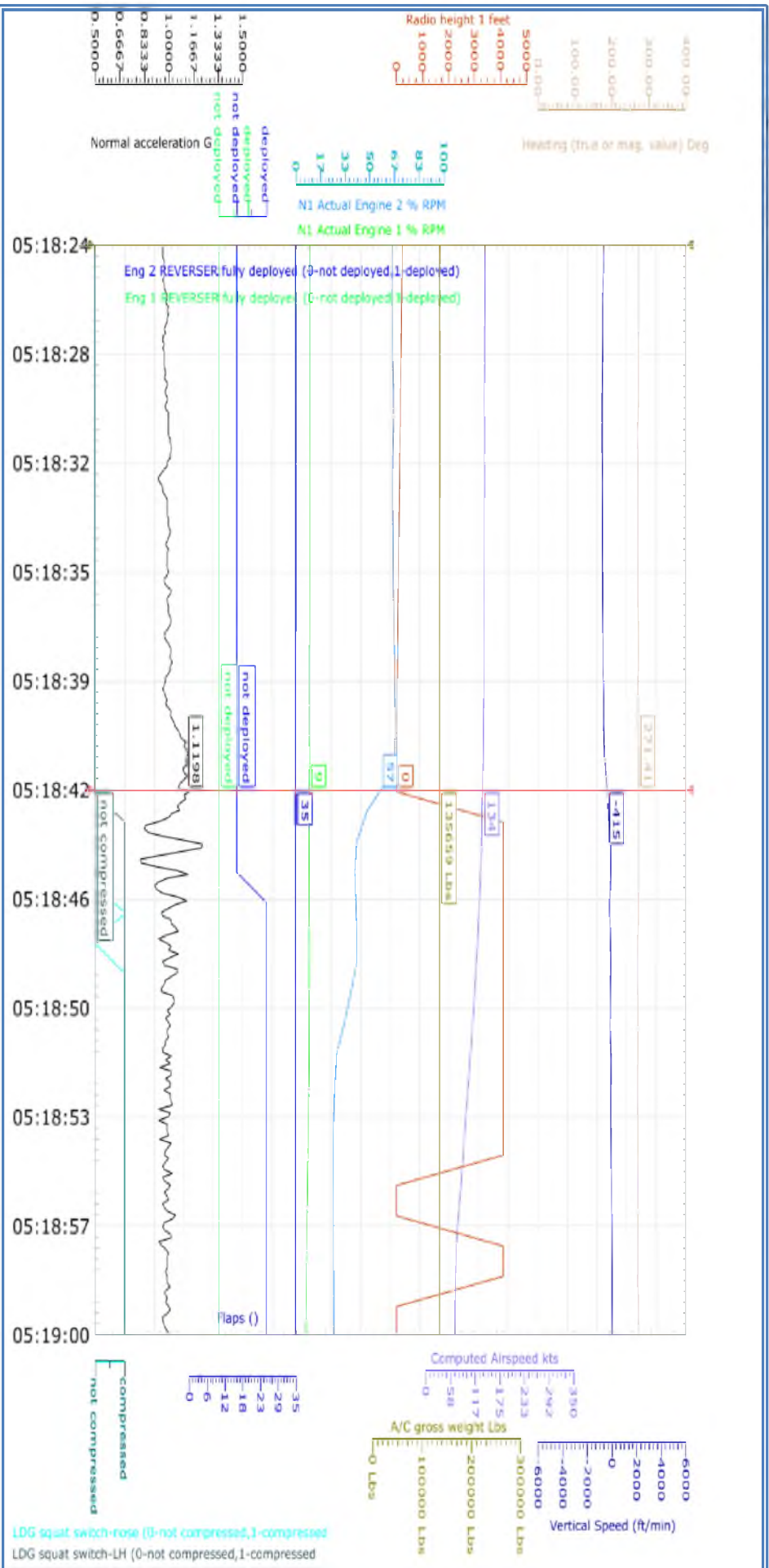



Flight Data Recorder Factual Report
LZ-FBC-22052021_EN

Aero Technic BG
 Sofia, Bulgaria 1540, Sofia Flight Training Ltd, office No8
 E-mail: management@aerotechnic-bg.com
<https://www.aerotechnic-bg.com/>

05:18:46 Thrust Reverser deployment. Engine 2 only

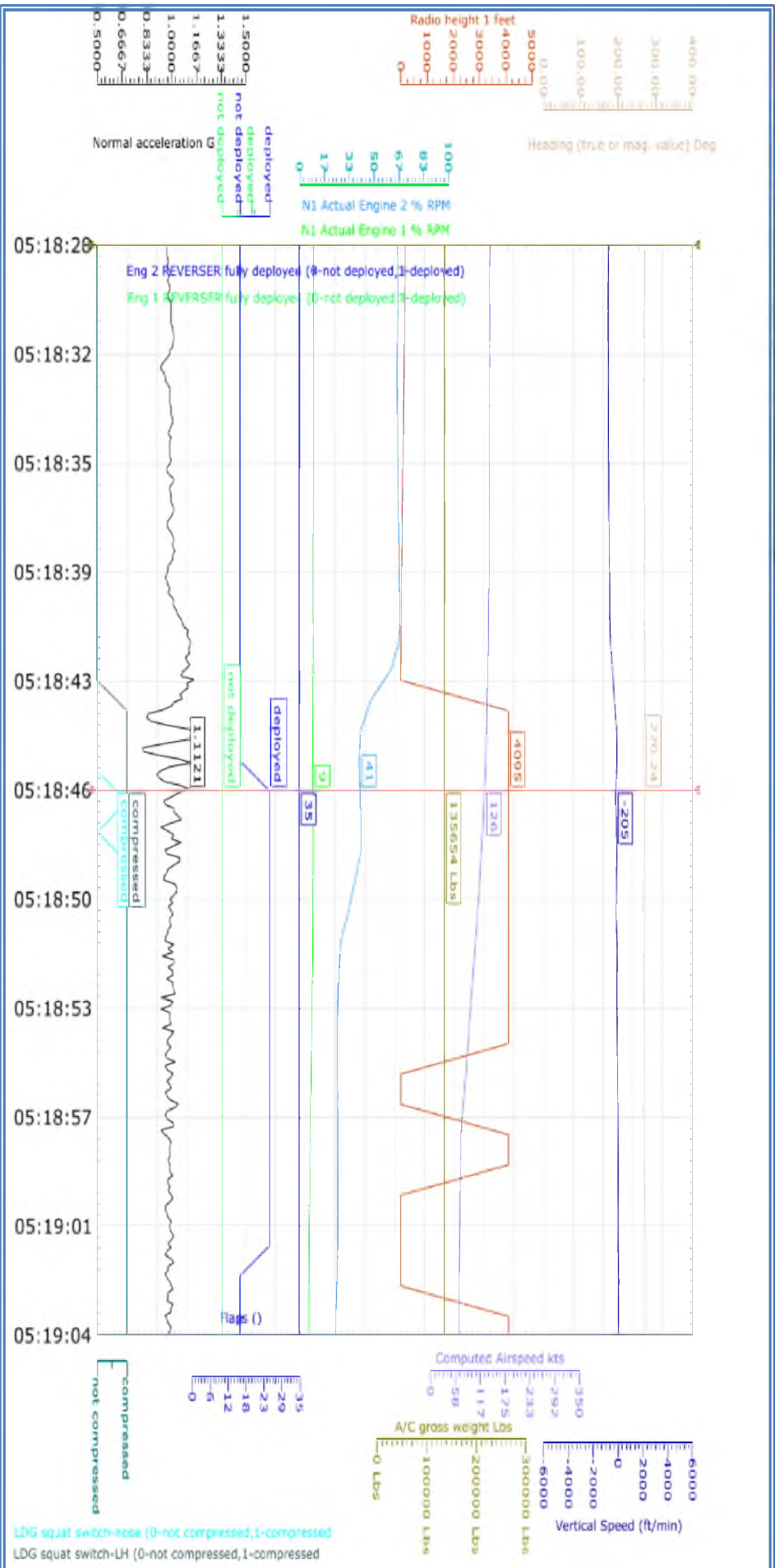



05:19:13 Evacuates Runway via taxiway F, K, M, J, N to STAND 16

FUEL QTY

L INNER 7007 Lbs

L OUTER 1408 Lbs

CENTRE 47 Lbs

R INNER 6425 Lbs

R OUTER 1472Lbs



Flight Data Recorder Factual Report
LZ-FBC-22052021_EN

Aero Technic BG
 Sofia, Bulgaria 1540, Sofia Flight Training Ltd, office No8
 E-mail: management@aerotechnic-bg.com
<https://www.aerotechnic-bg.com/>

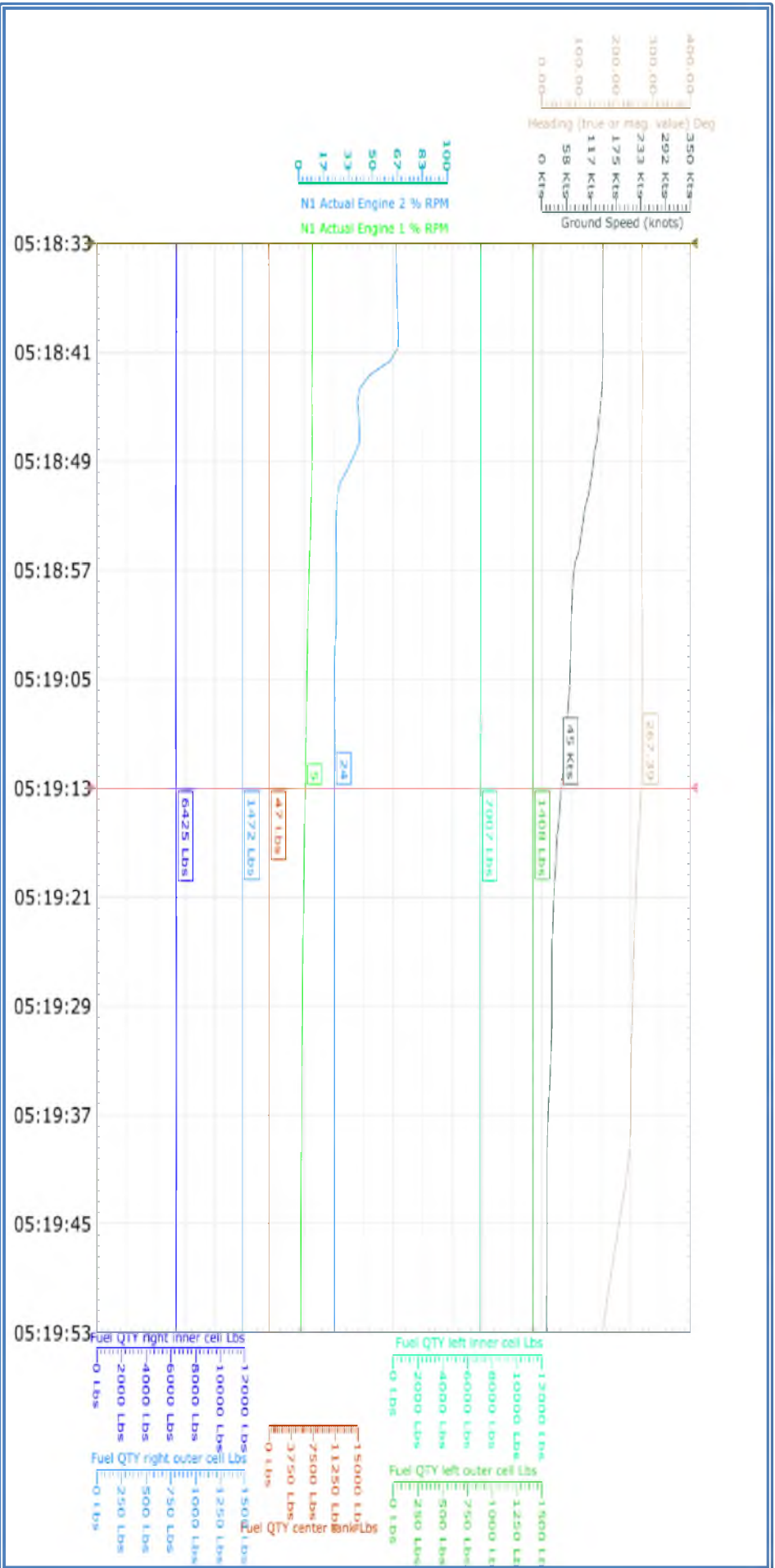





05:22:54 Engine 2 STOP

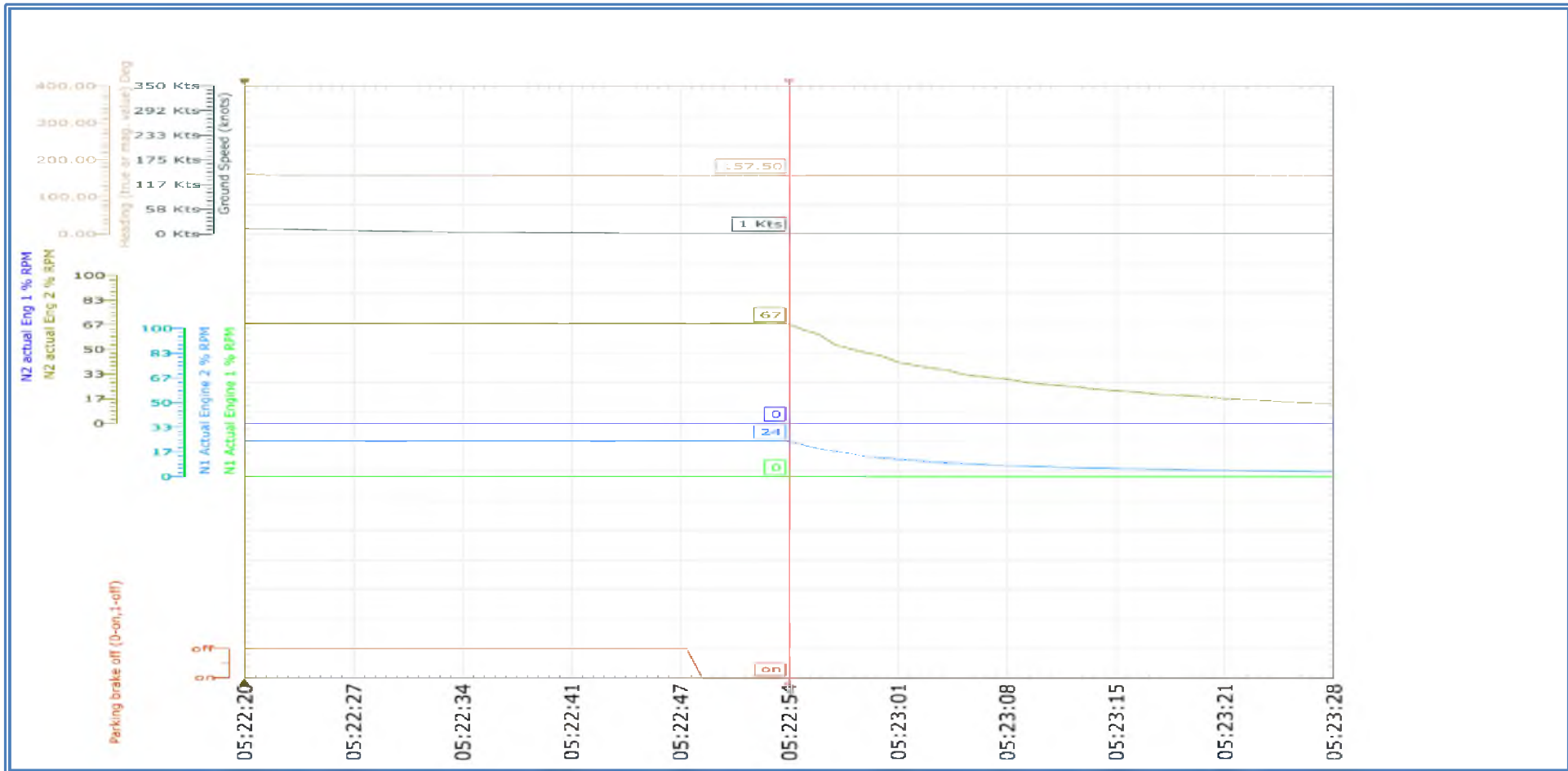

05:27:53 END OF RECORDING for the flight

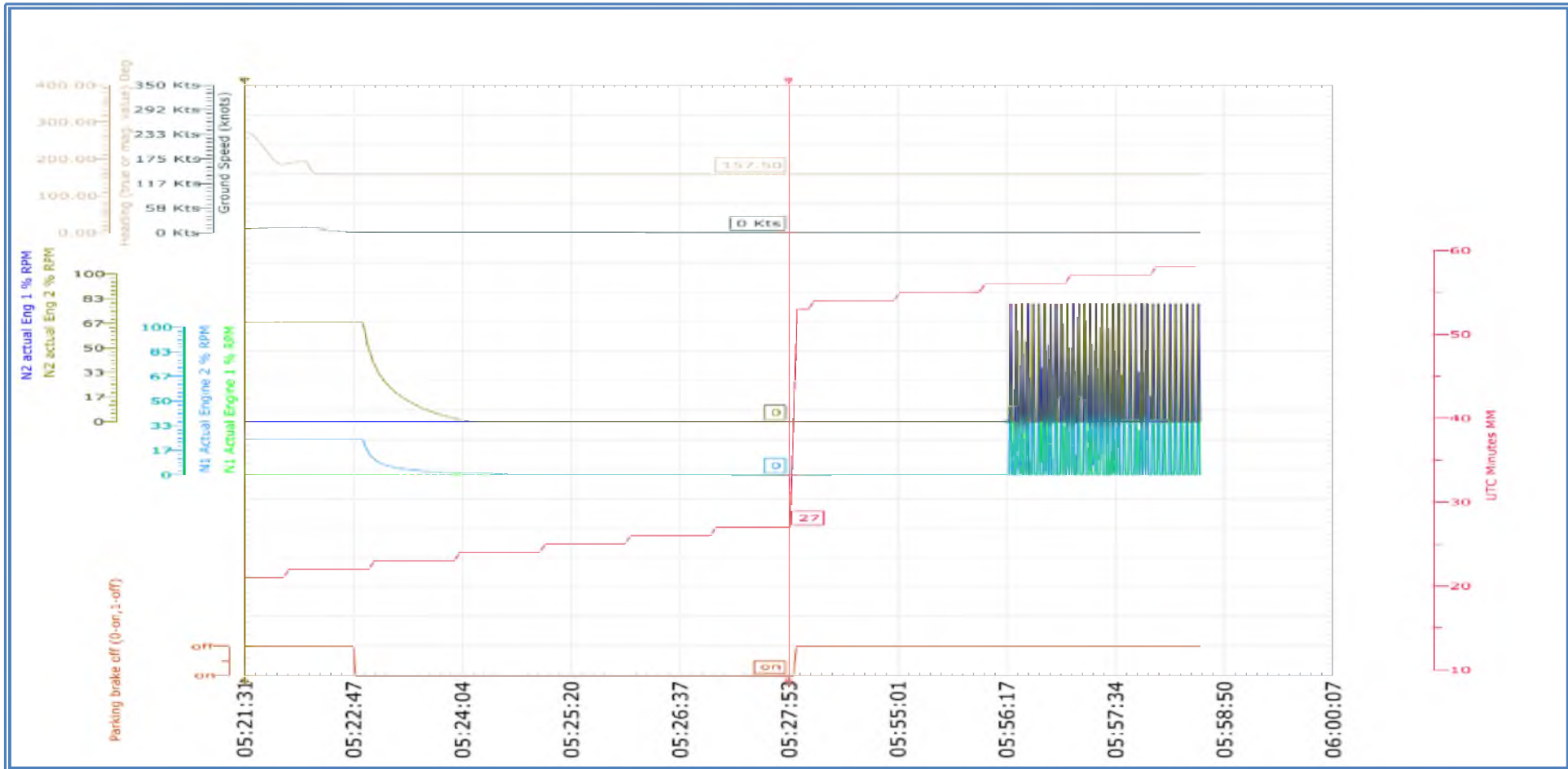



Flight Data Recorder Factual Report
LZ-FBC-22052021_EN

Aero Technic BG

Sofia, Bulgaria 1540, Sofia Flight Training Ltd, office No8

E-mail: management@aerotechnic-bg.com

<https://www.aerotechnic-bg.com/>

7. Legend

RWY- Runway

TDP- Touchdown Point

GND- Ground

WOW- Weight on Wheel